

# An LQG Approach to Systems with Saturating Actuators and Anti-Windup Implementation\*

Y. EUN, C. GÖKÇEK, P. T. KABAMBA and S. M. MEERKOV†

Department of Electrical Engineering and Computer Science, University of Michigan, Ann Arbor,  
MI 48109-2122, USA

(Received 23 April 2002)

This paper extends the LQG design methodology to systems with saturating actuators and shows that resulting linear controllers do not require an anti-windup implementation.

**Key words:** Saturating actuators; Disturbance rejection; LQR/LQG control; Anti-windup

## 1 INTRODUCTION

LQG is a useful tool for design of linear controllers. However, it is not applicable to systems with saturating actuators. In this situation, designers often use an indirect approach, which consists of selecting the LQG weights that force the resulting controller to operate appropriately in the linear region of the actuator and then implementing this controller using anti-windup [1–4]. This paper proposes a different, *i.e.*, direct approach, according to which the linear controller is designed explicitly taking into account saturation. This approach is referred to as SLQG, where S stands for “saturating”. We show subsequently that SLQG controllers do not require an anti-windup implementation, in the sense that adding any linear anti-windup cannot reduce the performance index.

Results obtained in this paper are based on the method of stochastic linearization [5–6], which is a quasi-linearization technique similar to describing functions. According to this method, the saturating actuator is replaced by a linear gain, which is a function of the variance of the signal at its input. Although this method is approximate, it is shown in [5–7], to be sufficiently precise, having errors well within 10% of the exact values of interest (in this work, the variance of the plant output). Since in practice the SLQG controller would have to operate with the real (rather than stochastically linearized) actuators, we investigate the properties of the closed loop system consisting of the plant, SLQG controller and the saturating actuator and show that this system inherits properties of the stochastically linearized one.

The outline of this paper is as follows: Section 2 presents the SLQG theory. Section 3 addresses the question of the utility of anti-windup implementation of SLQG controllers and shows that there is none. In Section 4, the conclusions are formulated. The proofs are outlined in the Appendix. More details can be found in [7].

---

\* This work has been supported by NSF Grant No. CMS-0073302.

† Corresponding author.

## 2 SLQG THEORY

### 2.1 Problem Formulation

Consider the system shown in Figure 2.1, where  $P(s)$  is the plant,  $C(s)$  is the controller,  $\varphi(u)$  is the saturation nonlinearity defined by

$$\varphi(u) = \alpha \operatorname{sat}\left(\frac{u}{\alpha}\right), \quad \alpha > 0, \tag{2.1}$$

$$\operatorname{sat}(\xi) = \begin{cases} +1, & \xi > +1, \\ \xi, & -1 \leq \xi \leq +1, \\ -1, & \xi < -1, \end{cases} \tag{2.2}$$

$A(s)$  describes the dynamics of the actuator,  $F_1(s)$  and  $F_2(s)$  are coloring filters, and  $H_1(s)$  and  $H_2(s)$  are weighting filters. Signals  $u, v, y \in \mathbb{R}$  are the commanded control, actual control and measured output, respectively,  $w_1, w_2 \in \mathbb{R}$  are standard uncorrelated white noise processes, and  $z_1, z_2 \in \mathbb{R}$  are the controlled outputs.

Assume that the system, excluding the controller, has the state space representation

$$\begin{aligned} \dot{x}_G &= Ax_G + B_1w + B_2\varphi(u), \\ z &= C_1x_G + D_{12}u, \\ y &= C_2x_G + D_{21}w, \end{aligned} \tag{2.3}$$

where  $x_G = [x_P^T \ x_A^T \ x_{F_1}^T \ x_{F_2}^T \ x_{H_1}^T \ x_{H_2}^T]^T$ ,  $w = [w_1 \ w_2]^T$  and  $z = [z_1 \ z_2]^T$ . Using the method of stochastic linearization, Eqs. (2.3) can be reduced to the following stochastically linearized form [7]:

$$\begin{aligned} \dot{\hat{x}}_G &= A\hat{x}_G + B_1w + B_2N\hat{u}, \\ \hat{z} &= C_1\hat{x}_G + D_{12}\hat{u}, \\ \hat{y} &= C_2\hat{x}_G + D_{21}w, \end{aligned} \tag{2.4}$$

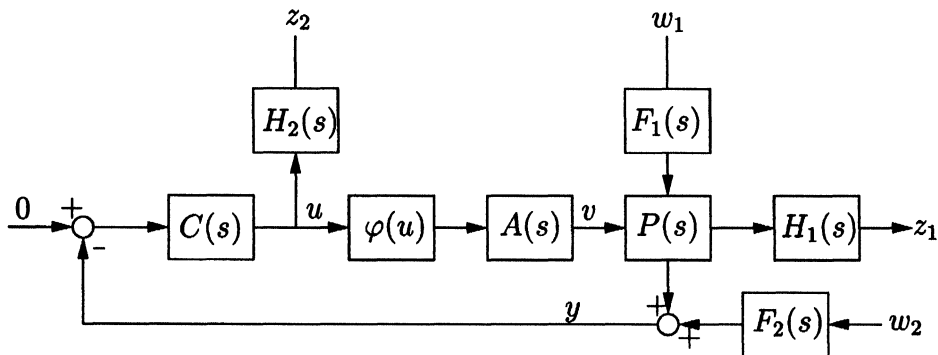

FIGURE 2.1 System model.

where

$$N = \operatorname{erf}\left(\frac{\alpha}{\sqrt{2}\sigma_{\hat{u}}}\right), \quad (2.5)$$

$$\operatorname{erf}(\xi) = \frac{1}{\sqrt{\pi}} \int_{-\xi}^{+\xi} \exp(-t^2) dt, \quad (2.6)$$

and  $\sigma_{\hat{u}}$  is the standard deviation of  $\hat{u}$ .

Introduce the performance index as the variance of the controlled output  $\hat{z}$ :

$$\sigma_{\hat{z}}^2 = \lim_{t \rightarrow \infty} E[\hat{z}(t)^T \hat{z}(t)]. \quad (2.7)$$

Finally, assume that the sought controller is of the form:

$$\begin{aligned} \dot{\hat{x}}_C &= M\hat{x}_C - L\hat{y}, \\ \hat{u} &= K\hat{x}_C, \end{aligned} \quad (2.8)$$

where the dimension of  $\hat{x}_C$  is the same as the dimension of  $\hat{x}_G$ .

**Problem 2.1** Develop a method for synthesis of controller (2.8) (i.e., for selecting matrices  $M, L, K$ ) so that performance index (2.7) is minimized along the trajectories of (2.4), i.e., develop a method for synthesis of SLQG controllers.

**Problem 2.2** Investigate the properties of the closed loop system consisting of (2.1), (2.3) and the SLQG controller (2.8).

## 2.2 Synthesis Equations

**ASSUMPTION 2.1** (a)  $(A, B_1)$  is stabilizable and  $(C_1, A)$  is detectable; (b)  $(A, B_2)$  is stabilizable and  $(C_2, A)$  is detectable; (c)  $D_{12} = [0 \ \sqrt{\rho}]^T, \rho > 0$  and  $D_{21} = [0 \ \sqrt{\mu}]$ ,  $\mu > 0$ ; (d)  $D_{12}^T C_1 = 0$  and  $B_1 D_{21}^T = 0$ ; (e)  $A$  has no eigenvalues in the open right-half plane.

With the exception of (e), these assumptions are standard in LQG theory [8].

**THEOREM 2.1** Under Assumption 2.1, there exists a unique proper controller (2.8) that internally stabilizes (2.4) and minimizes  $\sigma_{\hat{z}}^2$ . The minimum value of the cost is

$$\min_{M,L,K} \sigma_{\hat{z}}^2 = \operatorname{tr}\{C_1(P+R)C_1^T\} + \rho \frac{N^2}{(\rho+\lambda)^2} B_2^T Q R Q B_2, \quad (2.9)$$

and the controller is given by

$$\begin{aligned} K &= -\frac{N}{\rho+\lambda} B_2^T Q, \\ L &= -P C_2^T \frac{1}{\mu}, \\ M &= A + B_2 N K + L C_2, \end{aligned} \quad (2.10)$$

where  $(P, Q, R, S, N, \lambda)$  is the unique solution of the following system of equations

$$\begin{aligned}
 \lambda - \frac{\rho}{(\sqrt{\pi}/2)(N/\operatorname{erf}^{-1}(N)) \exp([\operatorname{erf}^{-1}(N)]^2) - 1} &= 0, \\
 A^T Q + QA - \frac{N^2}{\rho + \lambda} QB_2 B_2^T Q + C_1^T C_1 &= 0, \\
 AP + PA^T - PC_2^T C_2 P \frac{1}{\mu} + B_1 B_1^T &= 0, \\
 \left( A - \frac{N^2}{\rho + \lambda} B_2 B_2^T Q \right) R + R \left( A - \frac{N^2}{\rho + \lambda} B_2 B_2^T Q \right)^T + PC_2^T C_2 P \frac{1}{\mu} &= 0, \\
 \left( A - \frac{1}{\mu} PC_2^T C_2 \right)^T S + S \left( A - \frac{1}{\mu} PC_2^T C_2 \right) + \frac{N^2}{\rho + \lambda} QB_2 B_2^T Q &= 0, \\
 \left[ \frac{N^2}{\rho + \lambda} \right]^2 B_2^T QRQB_2 - \frac{\alpha^2 N^2}{2[\operatorname{erf}^{-1}(N)]^2} &= 0.
 \end{aligned} \tag{2.11}$$

As it follows from (2.11), the SLQG synthesis equations consist of Lyapunov and Riccati equations augmented by two transcendental relationships that account for the stochastically linearized gain  $N$  and the Lagrange multiplier  $\lambda$  associated with the constrained optimization problem.

**THEOREM 2.2** *Equations (2.11) can be solved with any desired accuracy in a finite number of steps by a bisection algorithm.*

Theorem 2.1 extends LQG to SLQG. Similarly, LQR can be extended to SLQR.

**THEOREM 2.3** *Under Assumption 2.1, there exists a unique controller*

$$\hat{u} = K \hat{x}_G \tag{2.12}$$

that internally stabilizes (2.4) and minimizes  $\sigma_z^2$ . The minimum value of the cost is

$$\min_K \sigma_z^2 = \operatorname{tr}\{C_1 R C_1^T\} + \rho \frac{N^2}{(\rho + \lambda)^2} B_2^T QRQB_2, \tag{2.13}$$

and a state feedback gain  $K$  that achieves this minimum is

$$K = -\frac{N}{\rho + \lambda} B_2^T Q, \tag{2.14}$$

where  $(Q, R, N, \lambda)$  is the unique solution of the following system of equations

$$\begin{aligned}
 \lambda - \frac{\rho}{(\sqrt{\pi}/2)(N/\operatorname{erf}^{-1}(N)) \exp([\operatorname{erf}^{-1}(N)]^2) - 1} &= 0, \\
 A^T Q + QA - \frac{N^2}{\rho + \lambda} QB_2 B_2^T Q + C_1^T C_1 &= 0, \\
 \left( A - \frac{N^2}{\rho + \lambda} B_2 B_2^T Q \right) R + R \left( A - \frac{N^2}{\rho + \lambda} B_2 B_2^T Q \right)^T + B_1 B_1^T &= 0, \\
 \left[ \frac{N^2}{\rho + \lambda} \right]^2 B_2^T QRQB_2 - \frac{\alpha^2 N^2}{2[\operatorname{erf}^{-1}(N)]^2} &= 0.
 \end{aligned} \tag{2.15}$$

In addition, if  $R$  is nonsingular, then the state-feedback gain  $K$  given by (2.14) is unique.

### 2.3 Properties of SLQG and SLQR Controllers

**THEOREM 2.4** *The SLQG and SLQR controllers lead to saturation activation quantified by*

$$\text{Prob}\{|\hat{u}| > \alpha\} = 1 - N, \quad (2.16)$$

where  $N$  is the solution of (2.11) or (2.15).

Thus, to minimize  $\sigma_z^2$ , the actuator should experience saturation to the degree defined by (2.16). The benefits of saturation activation have also been pointed out in [9].

**THEOREM 2.5** *Let Assumption 2.1 hold, assume  $C_1(sI - A)^{-1}B_1 \neq 0$ , and view  $\rho$  of Assumption 2.1(c) as a parameter. Denote the first term in the optimal value of the cost expression (2.13) as  $\gamma^2(\rho)$ , i.e.,*

$$\gamma^2(\rho) = \text{tr}\{C_1 R(\rho) C_1^T\}. \quad (2.17)$$

Then,  $\gamma^2(\rho)$  is an increasing function of  $\rho$  and

$$\lim_{\rho \rightarrow 0^+} \gamma^2(\rho) = \gamma_0^2 > 0. \quad (2.18)$$

Thus, Theorem 2.5 establishes performance limitation of the SLQR disturbance rejection problem in systems with saturating actuators. Even if the plant is minimum phase, the disturbance cannot be attenuated to any desired level, and must be consistent with the bound (2.18).

**THEOREM 2.6** *Consider the undisturbed version of system (2.3):*

$$\begin{aligned} \dot{x}_G &= Ax_G + B_2 \varphi(u), \\ y &= C_2 x_G. \end{aligned} \quad (2.19)$$

- (i) *Assume LQG controller (2.10) is used. Then,*
- $(x_G, x_C) = (0, 0)$  is the unique equilibrium point of (2.19), (2.10);*
  - this equilibrium is exponentially stable;*
  - if  $A$  and  $M$  are Hurwitz, all solutions of the closed loop system (2.19), (2.10) are bounded.*
- (ii) *Assume LQR controller (2.14) is used. Then,*
- $x_G = 0$  is the unique equilibrium point of (2.19), (2.14);*
  - this equilibrium is exponentially stable;*
  - if  $A$  is Hurwitz, all solutions of the closed loop system (2.19), (2.14) are bounded;*
  - an estimate of its domain of attraction is given by*

$$\chi = \left\{ x_G \in \mathbb{R}^{n_x} \mid x_G^T (\epsilon Q) x_G \leq \frac{4}{B_2^T (\epsilon Q) B_2} \right\}, \quad (2.20)$$

where  $n_x$  is the dimension of  $x_G$ , and

$$\varepsilon = \frac{N^2}{\rho + \lambda}. \quad (2.21)$$

## 2.4 Example

Following [10], consider the problem of roll oscillation suppression of a passenger ship disturbed by sea wave perturbations. In this problem, the actuator consists of two actively controlled wings attached to the stern of the ship. The travel of the wings is limited to  $\pm 18^\circ$ , which implies actuator saturation. The goal of control is to ensure that the standard deviation of the roll angle is below  $2.6^\circ$ .

The data provided in [10] leads to the following plant model:

$$\begin{aligned} \dot{x}_G &= \begin{bmatrix} -1.125 & -1.563 & 0.985 & 0 \\ 1 & 0 & 0 & 0 \\ 0 & 0 & -0.286 & -0.311 \\ 0 & 0 & 1 & 0 \end{bmatrix} x_G + \begin{bmatrix} 0 \\ 0 \\ 1 \\ 0 \end{bmatrix} w_1 + \begin{bmatrix} 1 \\ 0 \\ 0 \\ 0 \end{bmatrix} \text{sat}(u), \\ z_1 &= [0 \ 0.109 \ 0 \ 0] x_G, \\ y &= [0 \ 1.248 \ 0 \ 0] x_G. \end{aligned} \quad (2.22)$$

The open loop standard deviation of ship roll angle,  $z_1$ , is  $5.55^\circ$ . Thus, to achieve  $\sigma_{z_1} < 2.6^\circ$ , control is necessary.

Reference [10] proposed the controller of the form

$$C(s) = 35 \frac{s + 0.1}{s + 10}. \quad (2.23)$$

With this controller, the closed loop behavior results in  $\sigma_{z_1} = 2.64^\circ$  if saturation is ignored and in  $\sigma_{z_1} = 3.14^\circ$  in the presence of saturation.

To analyze if the performance specification  $\sigma_{z_1} < 2.6^\circ$  is achievable by any linear controller, we solved Eqs. (2.10), (2.11) for a very small  $\rho$  (specifically,  $\rho = 10^{-10}$ ). This resulted in  $\sigma_{z_1} = 2.30^\circ$ . Thus, the specification can be satisfied. To obtain a specific controller we choose  $\rho = 1.649 \times 10^{-4}$  and  $\mu = 10^{-4}$ . Then, Eqs. (2.10), (2.11) result in

$$C(s) = 94.60 \frac{(s - 0.089)(s^2 + 2.14s + 2.43)}{(s + 0.11)(s + 2.41)(s^2 + 7.82s + 34.65)}. \quad (2.24)$$

This controller leads to  $\sigma_{z_1} = 2.53^\circ$  and simulation of the closed loop system (2.22) with (2.24) confirms that  $\sigma_{z_1} = 2.56^\circ$ . Thus, the specification is satisfied.

## 3 SLQG CONTROLLER AND ANTI-WINDUP IMPLEMENTATION

### 3.1 Problem Formulation

As it was pointed out above, linear controllers designed without taking into account actuator saturation often require an anti-windup implementation. A typical structure of such an implementation is given in Figure 3.1, where  $C_1(s)$  is the anti-windup block.

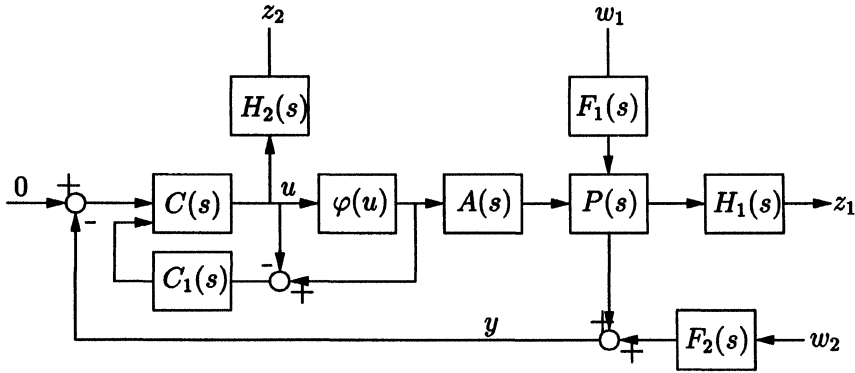

FIGURE 3.1 Feedback control system with anti-windup compensator.

The stochastically linearized version of the system of Figure 3.1 is shown in Figure 3.2. The problem addressed in this Section is as follows:

*Problem 3.1* Consider the system of Figure 3.2 and assume that  $C(s)$  is the SLQG controller (2.10), (2.11). Investigate whether there exists  $C_1(s)$  that leads to a smaller value of performance index (2.7) in comparison with that ensured by  $C(s)$  alone (i.e., without anti-windup).

### 3.2 Solution

**THEOREM 3.1** Assume  $C(s)$  is the SLQG controller. Then, there exists no  $C_1(s)$  that would yield a lower value of the performance index (2.7) than that ensured by  $C(s)$  alone.

Thus, Theorem 3.1 states that anti-windup implementation is not necessary if the controller  $C(s)$  is designed using SLQG.

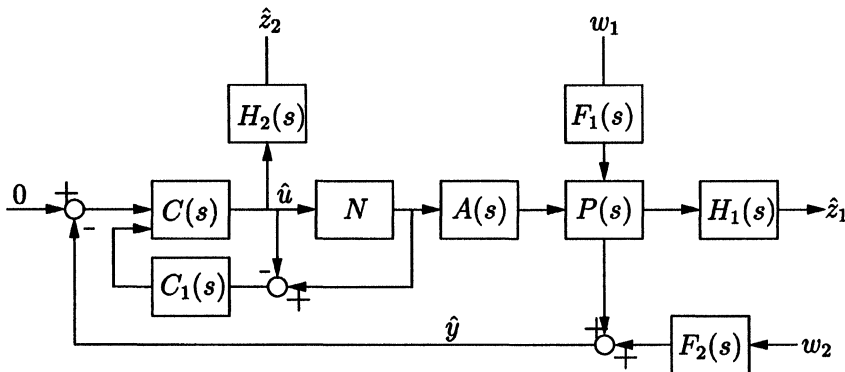

FIGURE 3.2 Stochastically linearized version of the system of Figure 3.1.

TABLE I Performances in Example.

	$\sigma_z^2$	$\sigma_z^2$	$((\sigma_z^2 - \sigma_z^2)/\sigma_z^2) \times 100\%$
$C(s)$	230.2	217.54	5.83%
$C(s)$ with anti-windup $C_1(s)$	234.5	220.28	6.49%

### 3.3 Example

Consider the system of Figure 3.1 with

$$A(s) = 1, \quad P(s) = \frac{1}{s+1}, \quad F_1(s) = \frac{15}{s+5}, \quad F_2(s) = 0.01, \quad H_1(s) = 10, \quad H_2(s) = 1. \quad (3.1)$$

Consider the SLQG controller

$$C(s) = \frac{269.67(s+6.92)}{(s^2+55.42s+1423.20)}, \quad (3.2)$$

and choose the anti-windup block  $C_1(s) = P(s)$ . This choice corresponds to the internal model based anti-windup suggested in [1]. Then, the two controllers  $C(s)$  and  $C_1(s)$  acting together yield  $\sigma_z^2 = 234.5$ , whereas the controller  $C(s)$  alone yields  $\sigma_z^2 = 230.2$ .

To verify the behavior of the real (rather than stochastically linearized) system with and without anti-windup, we simulated the system defined by (3.1) with controller  $C(s)$  alone and with  $C(s)$  and  $C_1(s)$  acting together and evaluated  $\sigma_z^2$  in each case. The results are summarized in Table I along with corresponding  $\sigma_z^2$ . These data confirm that the stochastically linearized system approximates well the original one (with accuracy of 5–7%) and the inclusion of anti-windup does not reduce the performance index.

## 4 CONCLUSIONS

An extension of LQG theory to systems with saturating actuators, referred to as SLQG, is developed. Although results reported here address SISO systems and amplitude saturation, extensions to MIMO case and rate saturation are readily available [7]. Also, similar developments for nonlinearities other than saturation can be carried out; some of them are briefly considered in [7]. It is shown that controllers, designed using the SLQG approach, do not require anti-windup.

## References

- [1] Hanus, R. (1988) Anti-windup and bumpless transfer: A survey, In: *Proceedings of the 12th IMACS World Congress*, Paris, France, July 1988. Vol. 2, pp. 59–65.
- [2] Zaccarian, L. and Teel, A. R., (2000) A benchmark example for anti-windup synthesis in active vibration isolation tasks and an  $\mathcal{L}_2$  anti-windup solution, *European Journal of Control*, 6(5).
- [3] Kothare, M. V., Campo, P. J., Morari, M. and Nett, C. N. (1994) A unified framework for the study of anti-windup designs, *Automatica*, 30(12), 1869–1883.
- [4] Crawshaw, S. and Vinnicombe, G. (2000) Anti-windup synthesis for guaranteed  $\mathcal{L}_2$  performance, *Proc. Conf. Dec. Contr.*, Sydney, Australia, pp. 1063–1068.
- [5] Roberts, J. B. and Spanos, P. D. (1990) *Random Vibration and Statistical Linearization*. NY: John Wiley and Sons.
- [6] Gelb, A. and Vander Velde, W. E. (1968) *Multiple-Input Describing Functions and Nonlinear System Design*. NY: McGraw-Hill.



- [7] Gökçek, C. (2000) Disturbance rejection and reference tracking in control systems with saturating actuators, *Ph.D. Thesis*. Department of Electrical Engineering and Computer Science, University of Michigan, Ann Arbor, MI.
- [8] Kwakernaak, H. and Sivan, R. (1972) *Linear Optimal Control Systems*. NY: Wiley Interscience.
- [9] Goldfarb, M. and Sirithanapipat, T. (1999) The effect of actuator saturation on the performance of PD-controlled servo systems, *Mechatronics*, **9**(5), 497–511.
- [10] Fortuna, L. and Muscato, G. (1996) A roll stabilization system for a monohull ship: Modeling, identification, and adaptive control, *IEEE Trans. Contr. Syst. Tech.*, **4**(1), 18–28.

## APPENDIX

*Proof of Theorem 2.1* The Lagrange multiplier technique is used. First, the regularity condition of the constraints is checked. Next, using the Lagrangian, (2.11) is derived. Finally, it is shown that equations in (2.11) have a unique solution  $(P, Q, R, S, N, \lambda)$  such that (2.4) with (2.8) is internally stable. Details can be found in [7]. ■

*Proof of Theorem 2.2* For any desired accuracy  $\varepsilon$ , the following algorithm provides the solution of (2.11). (a) start with  $N_1 = 0$  and  $N_2 = 1$ ; (b) let  $N = (N_1 + N_2)/2$ ; from (2.11), calculate  $\lambda$ ; solve Riccati equations for  $P$  and  $Q$ ; solve Lyapunov equations for  $R$  and  $S$ ; (c) calculate left hand-side of the last equation in (2.11) and call it  $\delta$ ; (d) if  $N_2 - N_1 < \varepsilon$ , then go to step (f); (e) if  $\delta < 0$ , then let  $N_1 = N$ , else let  $N_2 = N$ , and go to step (b); (f) calculate  $K, L, M$  from (2.10). Convergence result can be found in [7]. ■

*Proof of Theorem 2.3* Similar to the proof of Theorem 2.1. Details can be found in [7]. ■

*Proof of Theorem 2.4* Follows directly from (2.5). ■

*Proof of Theorem 2.5* Evaluating the derivative, it is shown that  $\gamma_0^2(\rho)$  is increasing and positive. Details can be found in [7]. ■

*Proof of Theorem 2.6* (i)-(a) Follows from the fact  $A + B_2K$  and  $A + LC_2$  are shown to be Hurwitz. (i)-(b) Proved by the Lyapunov's indirect method. (i)-(c) Proved by applying the triangle inequality to the solution of (2.19) with (2.10).

The proofs of (ii)-(a), (ii)-(b), (ii)-(c) are similar to those of (i)-(a), (i)-(b), (i)-(c), respectively. (ii)-(d) Proved by using the Lyapunov function  $V(x_G) = x_G^T(\varepsilon Q)x_G$ . See [7] for details. ■

The following lemma is needed to prove Theorem 3.1.

LEMMA A.1 *Under Assumption 2.1, the SLQG controller (2.10), (2.11) is the solution of the problem*

$$\min_{M,L,K} \sigma_2^2, \quad (\text{A.1})$$

where the minimization is over all controller of the form (2.8) with  $\dim(\hat{x}_C) \geq \dim(\hat{x}_G)$ .

*Proof* Let  $m = \dim(\hat{x}_C) - \dim(\hat{x}_G)$ .

Augmenting (2.4) by

$$\dot{\hat{x}} = A_1 \hat{x} + A_2 \hat{x}_G,$$

where  $A_1$  is an arbitrary  $m \times m$  Hurwitz matrix and  $A_2$  is an arbitrary  $m \times \dim(\hat{x}_G)$  matrix yields

$$\begin{aligned}\dot{\bar{x}} &= \bar{A}\bar{x} + \bar{B}_1 w + \bar{B}_2 N \hat{u}, \\ \hat{z} &= \bar{C}_1 \bar{x} + D_{12} \hat{u}, \\ \hat{y} &= \bar{C}_2 \bar{x} + D_{21} w,\end{aligned}\tag{A.2}$$

where

$$\bar{x} = \begin{bmatrix} \hat{x}_G \\ \hat{x} \end{bmatrix}, \quad \bar{A} = \begin{bmatrix} A & 0 \\ A_2 & A_1 \end{bmatrix}, \quad \bar{B}_i = \begin{bmatrix} B_i \\ 0 \end{bmatrix}, \quad \bar{C}_i = [C_i \quad 0], \quad i = 1, 2.\tag{A.3}$$

The state space representations (2.4) and (A.2) have identical input–output characteristics from  $\hat{u}$  and  $w$  to  $\hat{z}$  and  $\hat{y}$ . Therefore, they yield the same value of (2.7) with any controller. However, this augmentation leads to minimization over all *stabilizing controllers with dimensionality* ( $\dim(\hat{x}_G) + m$ ). Within this minimization, Assumption 2.1 is satisfied and, therefore, there exists a unique solution  $(\bar{P}, \bar{Q}, \bar{R}, \bar{S}, \bar{N}, \bar{\lambda})$  of Eq. (2.11) with matrices  $\bar{A}, \bar{B}_1, \bar{B}_2, \bar{C}_1, \bar{C}_2$  used instead of  $A, B_1, B_2, C_1, C_2$ . Thus, the SLQG controller for (A.2) is given by

$$\begin{aligned}\bar{M} &= \bar{A} + \bar{B}_2 \bar{N} \bar{K} + \bar{L} \bar{C}_2, \\ \bar{L} &= -\bar{P} \bar{C}_2^T \frac{1}{\mu}, \quad \bar{K} = -\frac{\bar{N}}{\rho + \bar{\lambda}} \bar{B}_2^T \bar{Q}.\end{aligned}\tag{A.4}$$

Let the SLQG controller for (2.4) be  $(M, L, K)$  and the associated matrices be  $(P, Q, R, S, N, \lambda)$ . Then,  $(\bar{P}, \bar{Q}, \bar{R}, \bar{S}, \bar{N}, \bar{\lambda})$  can be written in terms of  $(P, Q, R, S, N, \lambda)$  as follows:

$$\begin{aligned}\bar{P} &= \begin{bmatrix} P & P_2 \\ P_2^T & P_3 \end{bmatrix}, \quad \bar{Q} = \begin{bmatrix} Q & 0 \\ 0 & 0 \end{bmatrix}, \quad \bar{R} = \begin{bmatrix} R & R_2 \\ R_2^T & R_3 \end{bmatrix}, \quad \bar{S} = \begin{bmatrix} S & 0 \\ 0 & 0 \end{bmatrix}, \\ \bar{N} &= N, \quad \bar{\lambda} = \lambda,\end{aligned}\tag{A.5}$$

where  $P_2, P_3, R_2, R_3$  can be uniquely obtained from

$$0 = \bar{A} \bar{P} + \bar{P} \bar{A}^T - \bar{P} \bar{C}_2^T \bar{C}_2 \bar{P} \frac{1}{\mu} + \bar{B}_1 \bar{B}_1^T,\tag{A.6}$$

$$0 = \left( \bar{A} - \frac{\bar{N}^2}{\rho + \bar{\lambda}} \bar{B}_2 \bar{B}_2^T \bar{Q} \right) \bar{R} + \frac{1}{\mu} \bar{P} \bar{C}_2^T \bar{C}_2 \bar{P} + \bar{R} \left( \bar{A} - \frac{\bar{N}^2}{\rho + \bar{\lambda}} \bar{B}_2 \bar{B}_2^T \bar{Q} \right)^T.\tag{A.7}$$

Note that, since the matrices in (A.2) satisfy Assumptions 2.1, solutions of the Riccati and Lyapunov equations (A.6) and (A.7) exist.

Using (A.3) and (A.5), the SLQG controller (A.4) becomes

$$\bar{M} = \begin{bmatrix} M & 0 \\ A_2 - P_2^T C_2^T C_2 \frac{1}{\mu} & A_1 \end{bmatrix}, \quad \bar{L} = \begin{bmatrix} L \\ -P_2^T C_2 \frac{1}{\mu} \end{bmatrix}, \quad \bar{K} = [K \quad 0].\tag{A.8}$$

This implies that both  $(M, L, K)$  and  $(\bar{M}, \bar{L}, \bar{K})$  result in identical transfer function from  $\bar{y}$  to  $\bar{u}$ . In other words, the optimal controller does not need more than  $\dim(\hat{x}_G)$  states. Consequently, this implies that increasing the dimension of the SLQG controller does not reduce (2.7). ■

*Proof of Theorem 3.1* Within the framework of stochastic linearization, a linear anti-windup block  $C_1(s)$  and SLQG controller  $C(s)$  in Figure 3.2 can be combined into one controller that uses only measurement feedback. As a result, the dimension of combined controller is larger than that of the SLQG controller. Thus, it follows from the Lemma A.1 that the performance of the SLQG controller cannot be improved by anti-windup. ■



# Hindawi

Submit your manuscripts at  
<http://www.hindawi.com>

