

Research Article

The Comprehensive Study of Electrical Faults in PV Arrays

M. Sabbaghpur Arani and M. A. Hejazi

Electrical and Computer Engineering Department, University of Kashan, Kashan, Iran

Correspondence should be addressed to M. A. Hejazi; mhejazi@kashanu.ac.ir

Received 30 June 2016; Accepted 27 September 2016

Academic Editor: Ephraim Suhir

Copyright © 2016 M. Sabbaghpur Arani and M. A. Hejazi. This is an open access article distributed under the Creative Commons Attribution License, which permits unrestricted use, distribution, and reproduction in any medium, provided the original work is properly cited.

The rapid growth of the solar industry over the past several years has expanded the significance of photovoltaic (PV) systems. Fault analysis in solar photovoltaic (PV) arrays is a fundamental task to increase reliability, efficiency, and safety in PV systems and, if not detected, may not only reduce power generation and accelerated system aging but also threaten the availability of the whole system. Due to the current-limiting nature and nonlinear output characteristics of PV arrays, faults in PV arrays may not be detected. In this paper, all possible faults that happen in the PV system have been classified and six common faults (shading condition, open-circuit fault, degradation fault, line-to-line fault, bypass diode fault, and bridging fault) have been implemented in 7.5 KW PV farm. Based on the simulation results, both normal operational curves and fault curves have been compared.

1. Introduction

Renewable energy is energy which can be obtained from natural resources that can be constantly replenished like water, wind, sun rays, and so forth [1]. It is necessary to achieve more sustainable energy system. Among the most important renewable sources and most widely used across the globe is the solar energy [2, 3]. PV markets are growing fast because of their advantages such as long life of PV panel, installation in different geographical conditions such as impassible areas and mountains, usability on mobile hosts, easy maintenance, off-grid installing, and ability to connect to utility grid which have depicted a bright future for the use of photovoltaic system in the world [4, 5]. On the other hand, the rapid growth rate is mainly due to the need for alternatives to fossil fuel-based electricity generation, concerns over the global environment, reduced photovoltaics costs, and interests in distributed energy sources to improve power system reliability [6, 7]. The efficiencies of inverters which convert the direct current generated by the modules into alternate current are already close to maximum about 99 percent [8]. Therefore, no significant gains are possible from improving inverter efficiency. Alternately, PV array outputs can be increased by improving the efficiency of the PV modules. The last surveys have showed that the median values of efficiency of different modules technologies such as GaAs

(thin film), crystalline silicon, and Si (Amorphous) were close to 28.8, 25.6, and 10.2 percent, respectively [9, 10]. Improving efficiencies through better materials is an important field [11]. Another way to improve PV array output is to ensure that the array operates in optimal output conditions at all times. PV arrays once installed are expected to operate with minimal human intervention. PV arrays perform below optimum output power levels due to faults in modules, wiring, inverter, and so forth. Most of these faults remain undetected for long periods of time resulting in loss of power. Technicians sent to locate and fix the faults within an array need to take time consuming field measurements. So enquiries for lower cost and high efficiency-devices motivate the researchers to increase the reliability of PV system.

Fault analysis in the solar PV arrays is a fundamental task to eliminate any kind of dangerous and undesirable situations arising in the operation of PV array due to the presence of faults. They must be detected and cleared off rapidly. Without proper fault detection, noncleared faults in PV arrays not only cause power losses but also might lead to safety issues and fire hazards [12]. Photovoltaic systems are subjected to different sort of failures; thus, before starting monitoring system and fault diagnosis methods, it is necessary to identify what kind of failures can be found in the real system. The first step in this challenge is recognition and classification of all possible electrical faults in PV arrays.

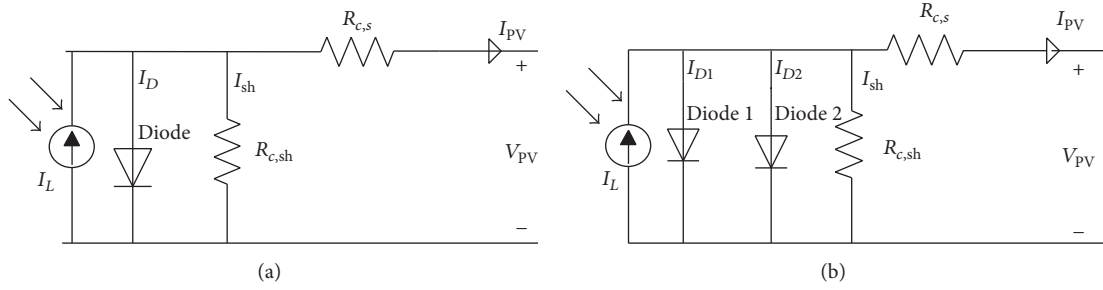

FIGURE 1: Equivalent circuits for (a) the one-diode model and (b) the double-diode model.

The fault detection methods for the PV system are classified in the visual (discoloration, browning, surface soiling, and delamination), thermal (thermal extraordinary heating), and electrical (dark/illuminated I - V curve measurement, transmittance line diagnosis, and RF measurement). Using electrical signatures is more advantageous and promising for the monitoring and diagnostic systems [13, 14]. This characteristic of electrical methods offers helpful data in diagnosing a PV cell's health. Furthermore, the I - V and P - V curves analyses are fundamental tool to understand the fault scenarios among PV strings and the impact of these fault in basic output parameters such as open-circuit voltage (V_{oc}), short-circuit current (I_{sc}), maximum power point voltage (V_{mpp}), and maximum power point current (I_{mpp}) in I - V and P - V curves.

In this paper in Section 1 the basics of PV modules model as electrical components are described. In Section 2 challenges to fault analysis in PV arrays are expressed. In Section 3 we introduce comprehensive classification of electrical faults in a PV system. Finally, based on the circuit-based simulation model, various types of faults will be developed by changing conditions or inputs in the simulation, and the I - V and P - V characteristics of faulted and clean PV array have been compared for each type of fault.

2. Background

The issue of modeling of PV arrays under electrical faults has been largely investigated in the literature and gets some certain results. A survey of state-of-the-art of ground, line-to-line, and arc fault detection is presented in [15].

In [16] Chao et al. developed a circuit-based simulation model of a photovoltaic panel using the PSIM software. A 3 kW PV array system was established using extended correlation function to identify the different fault types of the PV system. In [17] Takashima et al. used earth capacitance measurement to locate faults in PV module arrays. Furthermore, in another study [14], they experimentally studied earth capacitance measurement and Time-Domain Reflectometry (TDR) to detect degradation (increase in series resistance between the modules) and the fault position in the string. In [18] Yagi et al. developed a diagnostic technology for PV systems based on statistically analyzed data to detect shading effect and inverter failure in PV arrays. In [19] unique fault evolution in a PV array during night-to-day transition

and effect of a maximum power point tracker on fault current have been discussed.

In [20] Yamada et al. conducted simulations for PV modules on the reflection loss using the optical performance of a four-layer encapsulation. In [21] Nguyen studied impact of varying position, different levels of solar irradiation, and the performance of bypass diode under nonuniform irradiation levels. In [22] Firth et al. developed novel analysis techniques to identify four types of faults: sustained zero efficiency faults; brief zero efficiency faults; shading; and nonzero efficiency nonshading faults. Three independent applications to measure the effects of soiling have been suggested by Hammond et al. in [23]. In [16, 24] only power versus voltage (P - V) characteristics is simulated for a few types of faults in a PV array. In addition, [25] discusses the MPPT reliability of a PV array under partial shading rather than faults in the array.

In none of previous studies mentioned above comprehensive classification of electrical faults scenarios in the PV system and the impact of all possible faults on the I - V and P - V curves have been performed properly.

3. Modeling and Simulation of PV Modules

3.1. Models for Solar Cells. Because of the nonlinear I - V characteristics of solar cells, it is not appropriate to simply model them as a constant voltage source or a constant current source. The electrical performance of a photovoltaic cell can be approximated by the equivalent circuit shown in Figures 1(a) and 1(b). The one-diode model and the double-diode model are most commonly used to describe the electrical behaviors of solar cells [26, 27].

In this paper we adopt the one-diode model for solar cells in simulation, because the one-diode model has several advantages over the double-diode model such as enough accuracy for steady-state and fault analysis for PV modules in system level, data available for the most PV modules in market, and rapid responses in simulation environment [28].

Based on the properties of p - n semiconductors and one-diode model, the I - V characteristics of a PV panel with N_s cells are characterized using the following equation:

$$I = I_L - I_S \left(\exp \left[\frac{q(V + IR_{c,s})}{N_s AkT} \right] - 1 \right) - \frac{V + IR_{c,s}}{R_{c,sh}}. \quad (1)$$

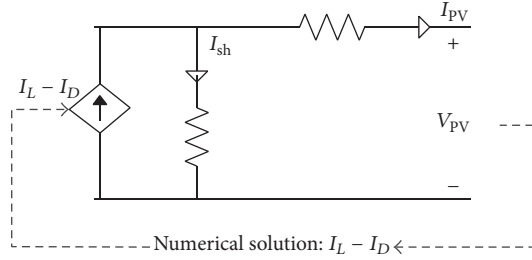

FIGURE 2: The numerical one-diode model for a PV module.

The dependence of the photocurrent on the irradiance (G) and cell temperature (T) can be described by the following empirical equation [11, 26, 27]:

$$I_L = \{I_{L0} + C_T (T - T_r)\} \frac{G}{G_0}. \quad (2)$$

The reverse saturation current I_S varies with solar cell surface temperature (T) [11, 26, 27]. It can be described by

$$I_S = I_{S0} \left(\frac{T}{T_r}\right)^3 \exp \left\{ \frac{qE_g}{kA} \left[\frac{1}{T_r} - \frac{1}{T} \right] \right\}. \quad (3)$$

Depending on the semiconductor material used for PV modules, E_g may have different values. Usually E_g is approximate 1.12 eV for crystalline silicon, 1.03 eV for copper indium diselenide (CIS), 1.7 eV for amorphous silicon, and 1.5 eV for cadmium Telluride (CdTe) under room temperature [11, 26, 27].

3.2. Modeling Algorithm. In real working conditions, solar cells packaged in the same module usually have almost the same irradiance conditions. For these reasons, assume that all the solar cells in each PV module have identical characteristics and working conditions. Thus, a PV module can be viewed as a basic unit consisting of identical solar cells. Therefore, modeling and simulation of PV modules become key steps for PV system normal and fault analysis. A bypass diode is usually connected in parallel across multiple cells to improve operation of solar system under nonuniform condition.

According to the one-diode model of PV modules in Figure 2, by using voltage V_{PV} , T , and G as input parameters, the modeling algorithm solves equations to find the mathematical solution for I and feeds the solution to a controlled current source in Figure 2. Figures 3(a) and 3(b) show the model for PV modules in MATLAB/Simulink. Using the widely used one-diode model for each individual solar panel, this paper builds simulation PV array (7.5 kW) in MATLAB/Simulink consisting of 6×5 PV panels that is capable of studying faults among panels. The related parameters of each PV panel under STC ($G = 1000 \text{ W/m}^2$ and $T = 25^\circ\text{C}$) are $P_{mpp} = 250 \text{ W}$, $V_{mpp} = 31 \text{ V}$, $I_{mpp} = 8.07 \text{ A}$, $N_s = 20$, $V_{oc} = 37.92 \text{ V}$, and $I_{sc} = 8.62 \text{ A}$ and $C_T = -0.33\%/^\circ\text{C}$. As shown in Figure 3(b), panels connected in parallel increase the current and those connected in series provide greater output voltages.

4. Challenges to Fault Analysis

Only PV array has been considered as source of electrical fault in this paper. According to National Electrical Code Standard [29], fuses blow when the fault currents that flow through them become greater than at least 1.56 times their rated short-circuit current. However, because of the nonlinear I - V characteristics, the current-limiting nature of PV arrays, high fault impedances, low irradiance conditions, PV grounding schemes, or MPPT of PV inverters faults in PV arrays may not be cleared [30]. But because of some factors such as environmental conditions (varying irradiance level and temperature), PV array configurations and fault locations, aging, hot-spot, mismatch faults unique to PV technology, and MPPT effect, fault analysis would be more complicated and conventional protection devices may not be able to clear faults correctly. Since PV array normal operation can be affected by the presence of faults that reduce power output and cause potential damage to the array, so analysis of the I - V curves for describing the effect of the faults that occur in PV arrays is very important.

5. Typical Faults

Since some of the electrical faults, such as mismatches, occur in all arrays at all times, they result in available DC power from the array being significantly below predicted levels. Table 1 shows the most common types of fault in a PV system.

6. Curves and Interpretation

A typical solar PV array with 6×5 PV modules (rated at 7.5 kW) is simulated, which consists of 6 modules in series per string and 5 strings in parallel. MATLAB/Simulink models of PV array (Figure 3) under electrical faults are developed to study the performance of the faulted PV array. According to Table 1, the most frequent faults are major catastrophic failures in PV arrays which are ground faults, line-to-line faults, and arc faults [15]. This research studies six common fault types from Table 1 in 12 cases and compared the results with the normal condition. The characteristics of the PV panel with different types of faults are shown in Figures 4–9.

6.1. Partial Shading (F1). The shading patterns can be very complicated due to no uniform insolation. Two identical

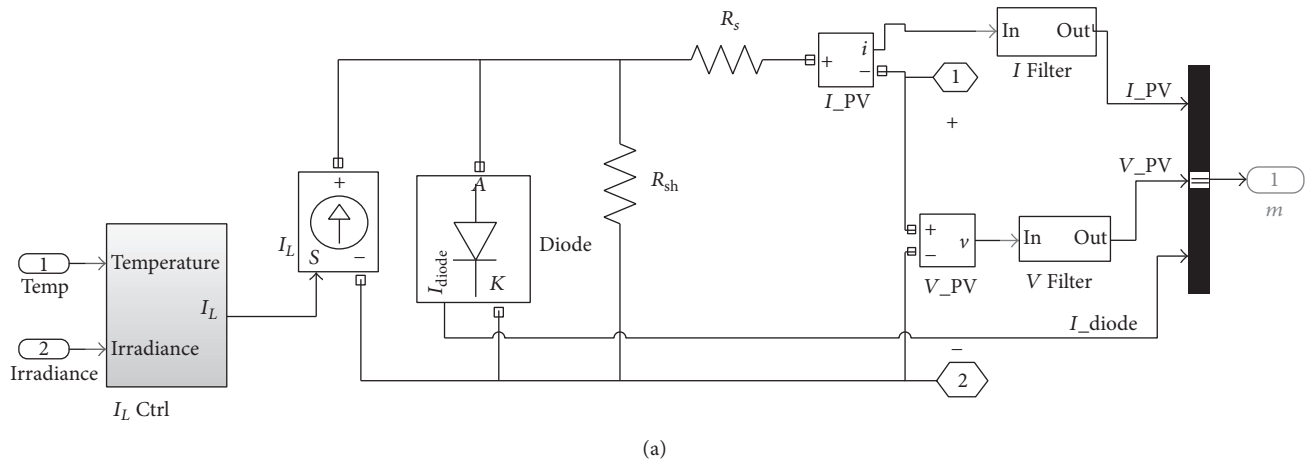

(a)

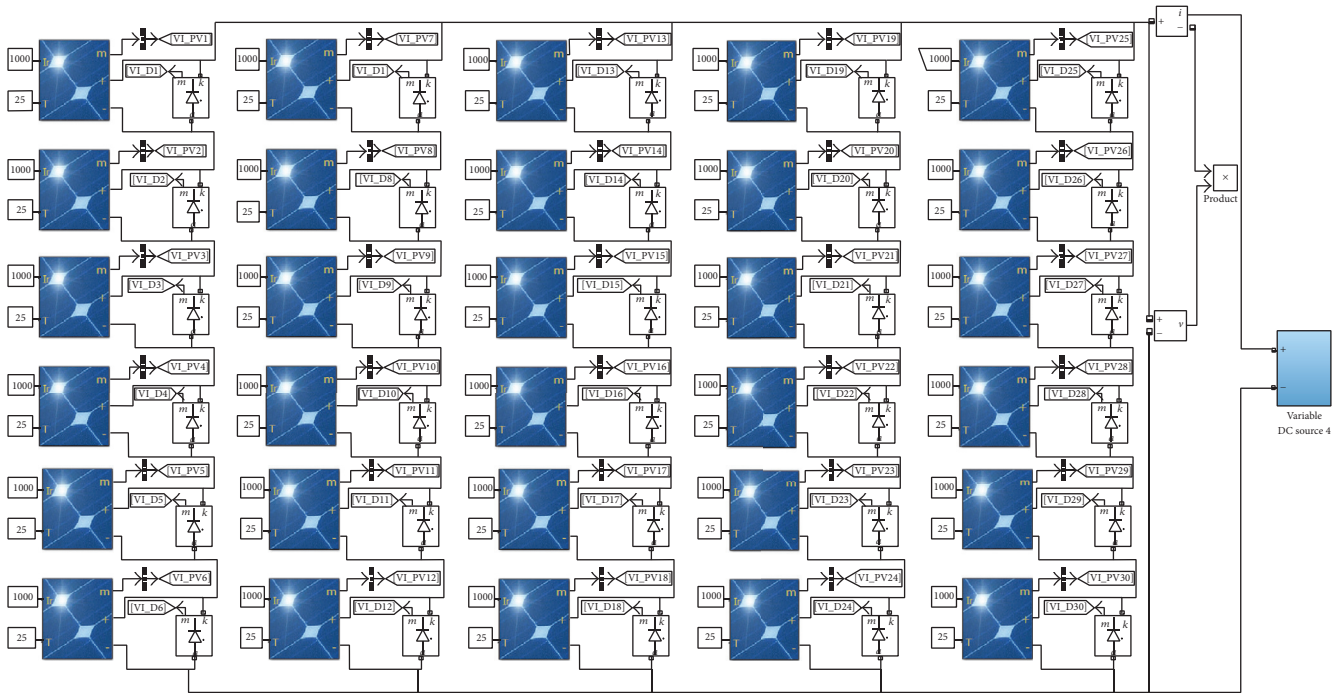

(b)

FIGURE 3: (a) Equivalent circuit of a solar and (b) a schematic diagram of a PV farm system with 6×5 modules.

PV arrays are used for comparison. One PV array with an arbitrary shading pattern is divided into two groups. In Case 1 the half of string one has been shaded with irradiance density $G = 800 \text{ W/m}^2$ and in Case 2 shaded modules receive two different insulations, $G = 500$ and 800 W/m^2 . I - V and P - V characteristics of these two cases are illustrated in Figure 4 for fault analysis. Under partial shading conditions, the short-circuit current for two cases remains identical, while the open-circuit voltage slightly decreases with the increase in the number of shaded modules. I - V curves of all shaded groups have multiple steps, while P - V curves of shaded groups are characterized by multiple peaks, whose number is equal to the number of solar insolation levels received by string, respectively. The results indicate that the higher number of shaded solar modules is the lower value of power output and the position of maximum power point does not depend on

location of modules under shadow. The surface temperature of solar cell is assumed to remain 298°K .

6.2. Line-to-Line Fault in a PV Array under STC (F9). As shown in Figure 5, line-to-line faults could happen inside PV arrays and potentially may involve large fault current or dc arcs. This research focuses on line-to-line faults, which are defined as an accidental short-circuiting between two points in the array with different potentials. In the following simulations, two cases are studied, a line-to-line fault with 2 modules (Case 3) and a line-to-line fault with 4 modules (Case 4). When a line-to-line fault occurs, the I - V curve of the faulted PV string will change accordingly. Since the faulted string has 4 number of modules less, it will have an open-circuit voltage reduced by $4x V_{oc}$. But the short-circuit current remains the same as other normal strings at I_{sc} .

TABLE 1: Classification and definition of faults in PV system based on location and structures.

| Part | Fault type | | Description | |
|------|-------------------------------|--------------------------------------|---|--|
| DC | Mismatch faults | Partial shading [21, 31] | F1 | Presence of trees, overhead power lines, or nearby buildings |
| | | Uniform irradiance distribution [32] | F2 | Various irradiance intensity during the day |
| | | Soiling [23] | F3 | The bird droppings and dirt on the surface of a PV module |
| | | Snow covering and hot spot [33, 34] | F4 | The worst temperatures depending on the geographical location and different weather conditions |
| | Earth fault | Upper ground fault [35, 36] | F5 | An unintentional path to ground with zero fault impedance occurs between the last two modules at PV string |
| | | Lower ground fault [35, 36] | F6 | An unintentional path to ground with zero fault impedance occurs between the 2nd and the 3rd two modules at PV string with large backfeed current |
| | Arc fault | Series arc fault [37, 38] | F7 | An arc fault due to discontinuity in any of the current carrying conductors resulting from solder disjoint, cell damage, corrosion of connectors, rodent damage, abrasion from different sources |
| | | Parallel arc fault [37, 38] | F8 | Insulation breakdown in current carrying conductors |
| | Line-to-line faults [19, 35] | F9 | An accidental short-circuit between two points in a string with different potentials | |
| | Bypass diode faults [39] | F10 | Short-circuit in case of incorrect connection | |
| | Degradation faults [40] | F11 | Yellowing and browning, delamination, bubbles in the solar module, cracks in cells, defects in antireflective coating and delamination over cells and interconnections lead to degradation and increasing of the internal series resistance | |
| | Bridging fault [19, 39] | F12 | Low- resistance connection between two points of different potential in string of module or cabling | |
| | Open-circuit fault [41] | F13 | Physical breakdown of panel-panel cables or joints, objects falling on PV panels, and loose termination of cables, plugging and unplugging connectors at junction boxes | |
| | MPPT faults [42, 43] | F14 | Problem in MPPT charge controllers | |
| | Cabling faults [44] | F15 | — | |
| Ac | Inverter faults [45] | F16 | Failure of each component of inverter such as IGBTs, capacitors, and drive circuitry can result in inverter failure | |
| | Sudden natural disasters [46] | F17 | Total blackout due to Lightning, storm, and so forth | |

6.3. *Bypass Diode Fault in a PV Array under STC (F10)*. Assume in Case 5 that one bypass diode is conducted or shorted and in Case 6 two bypass diodes are shorted. I - V and P - V characteristics of these two cases are shown in Figure 6. Even if only one full module is shorted by bypass diode, the maximum power and V_{oc} of the PV array drops significantly and short-circuit current remains the same as other normal strings.

6.4. *Degradation Fault in a PV Array under STC (F11)*. The reason for power degradation could be the increase in the series resistance between the modules due to decreased adherence of contacts or corrosion caused by water vapor. In this case, two different resistance values are considered. Group one (Case 7) has small resistance $R_1 = 1$ ohm and another group (Case 8) has larger resistance with $R_2 = 2$ ohm.

This PV array with resistance is compared with the normal PV array, shown in Figure 7. Although the open voltage

and short current do not change much under these different conditions, the maximum power point is reduced due to increase in resistance. Therefore, an increase of the internal series resistance can result in degradation of the peak power.

6.5. *Bridging Fault in a PV Array under STC (F12)*. In simulations, bridging fault or line-to-line faults with zero fault impedance are solid faults that occur immediately. In Figure 8, there is a bridging fault with one-module level difference between String 1 and String 2, which lead to unbalanced currents among PV array defined as bridging fault with small voltage difference (Case 9). Bridging fault with large voltage difference is a line-to-line fault with three-module level difference between String 1 and String 2 expressed as Case 10. Bridging faults usually involve reduced array voltage (V_{oc}) but have much small reduction in array current (I_{sc}). The fault with larger voltage difference between two fault

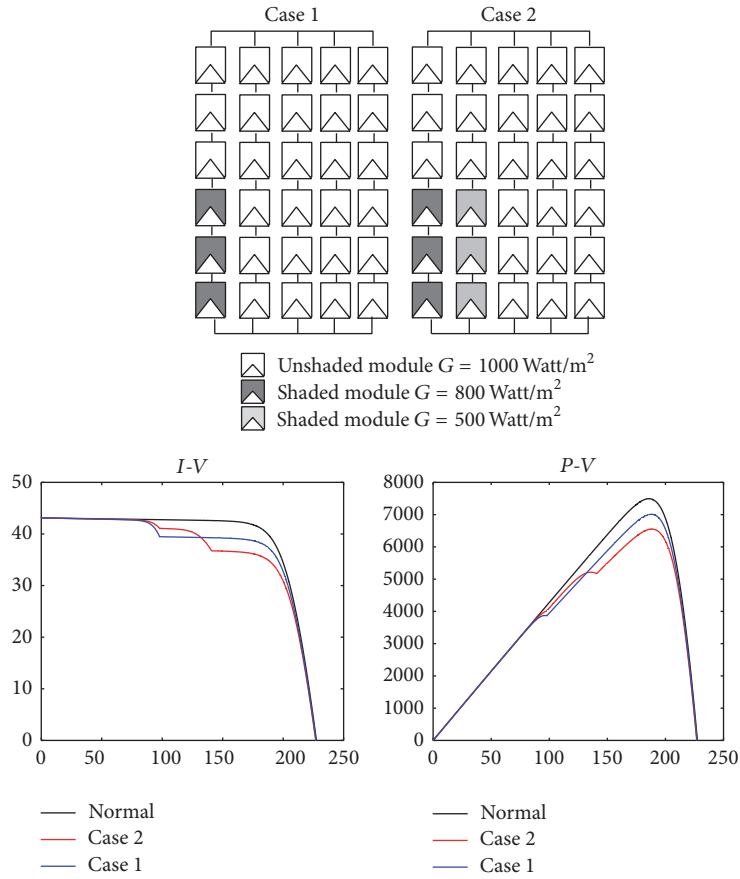

FIGURE 4: The PV array configuration for shading.

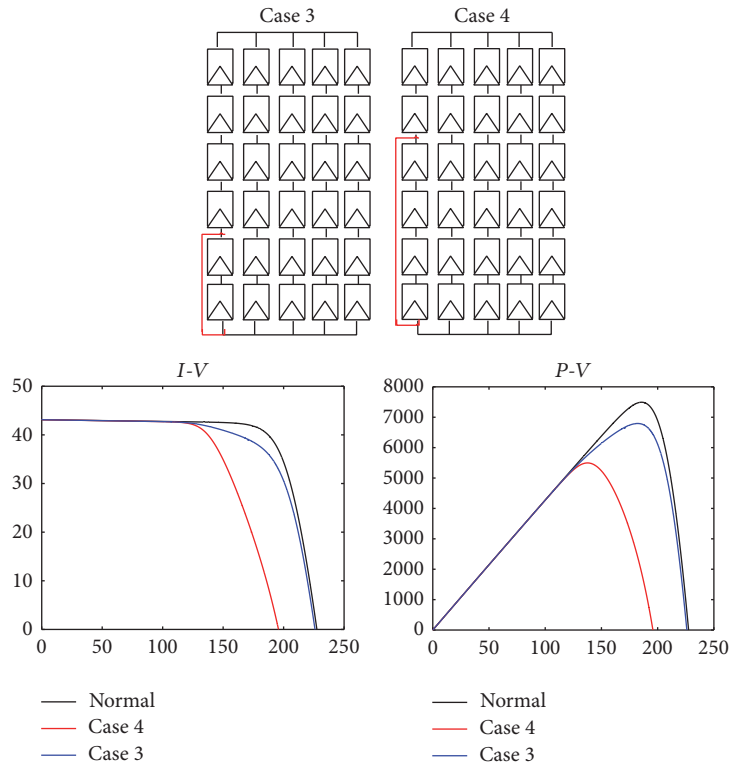

FIGURE 5: The PV array configuration for line-to-line fault.

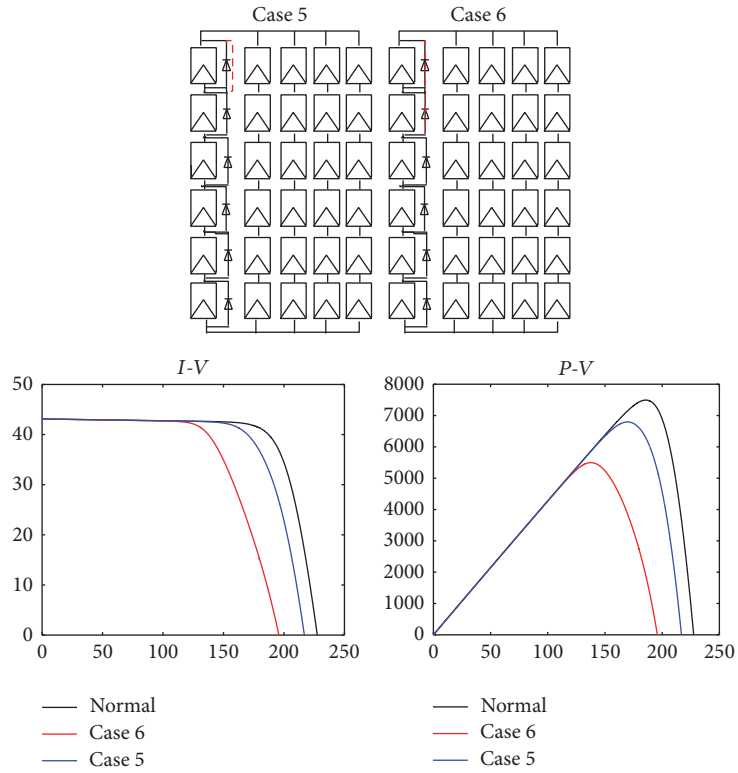

FIGURE 6: The PV array configuration for bypass diode short circuit.

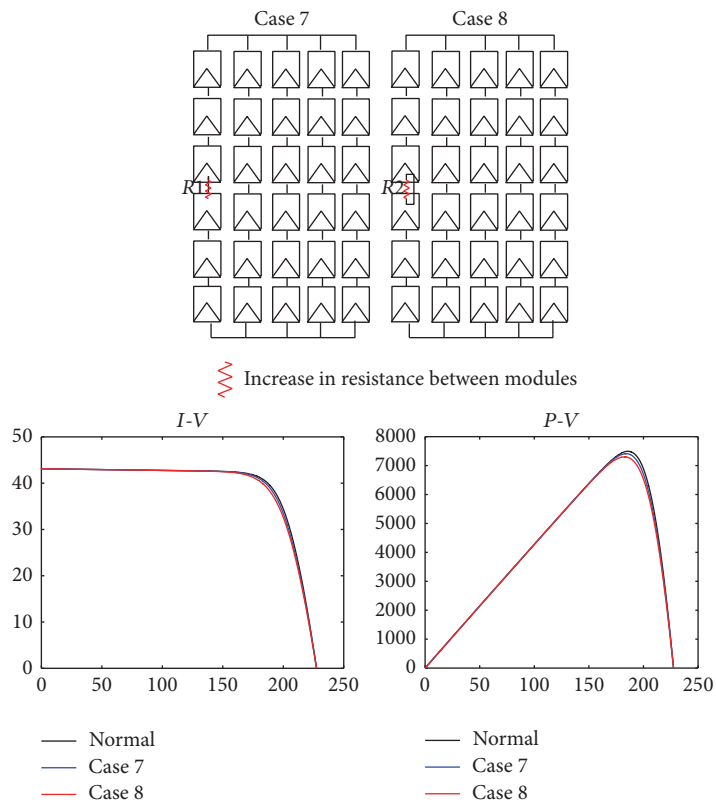

FIGURE 7: The PV array configuration for resistance between modules.

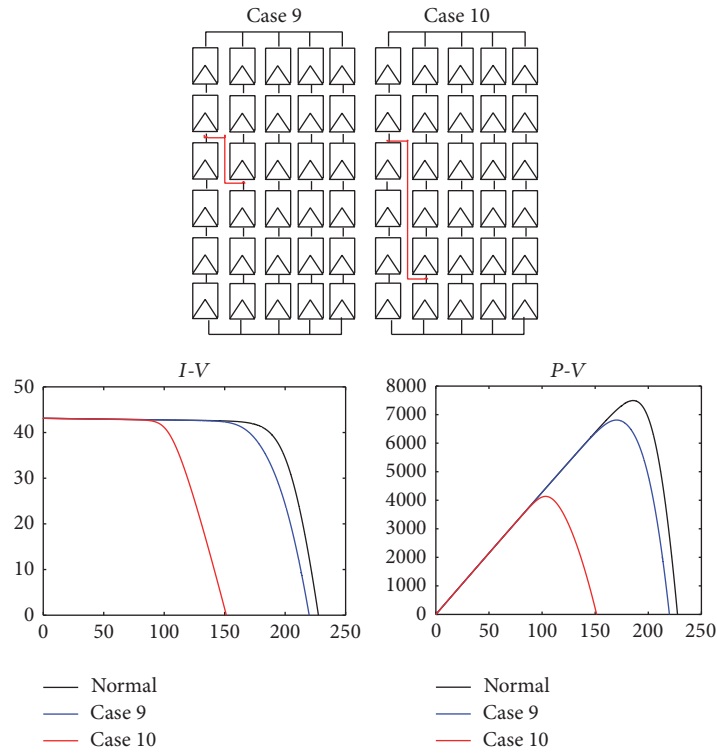

FIGURE 8: The PV array configuration for bridge fault.

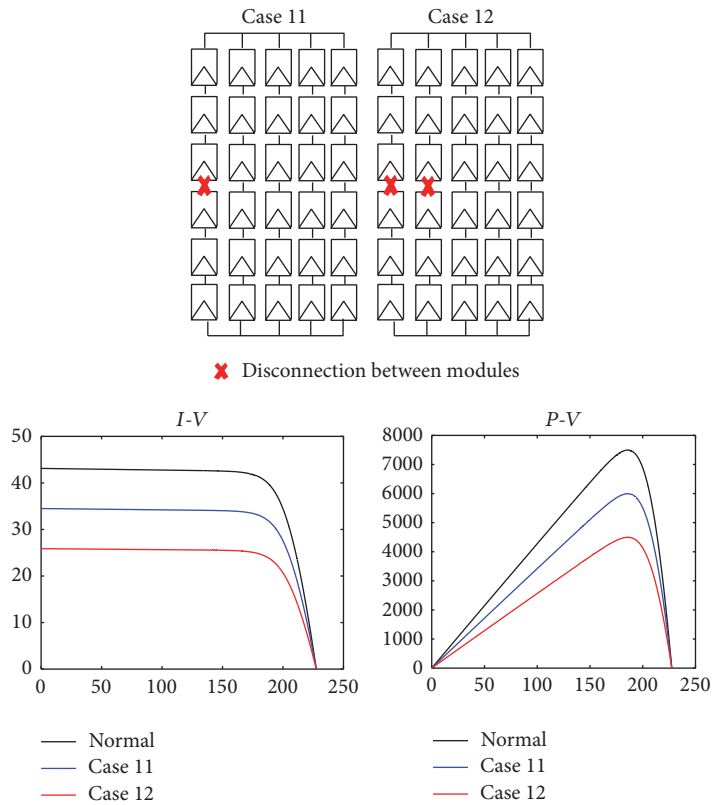

FIGURE 9: The PV array configuration for string disconnection.

points will lead to larger reduction in V_{oc} and I_{mpp} and V_{mpp} .

6.6. *Open-Circuit Fault in a PV Array under STC (F13)*. An open-circuit fault is an accidental disconnection at a normal current-carrying conductor. In this section, assume in Cases 11 and 12 that PV arrays have a disconnection problem in one string and two strings, respectively, and then the I - V and P - V characteristics have been compared with array without any disconnection under normal condition, as shown in Figure 9. The open voltage of these cases remains almost the same, while the short current and maximum power decrease linearly with the increase in the number of disconnected strings.

7. Conclusions

In this paper, a comprehensive definition of faults in DC side of PV system based on location and structure is presented. The performance of a typical PV array has been investigated under typical fault conditions such as shading condition, open-circuit fault, degradation fault, line-to-line fault, bypass diode fault, and bridging fault. To better visualize the PV data under normal and fault conditions, the I - V and P - V characteristics of the array have been evaluated. The off-line method used in this research can distinguish many types of different faults but cannot detect the location of the fault within the PV array. It would be useful to develop special MPPT schemes to track the maximum peak under these conditions and further methods capable of determining these locations.

Nomenclature

| | |
|--------------|--|
| MPPT: | Maximum power point tracer |
| STC: | Standard test condition |
| I : | Solar cell current (A) |
| V : | Solar cell voltage (V) |
| I_L : | Light-generated current (A) |
| I_D : | Diode current (A) |
| I_{sh} : | Shunt resistance current (A) |
| I_S : | Saturation current of the diode (A) |
| $R_{c,s}$: | Solar cell series resistance (ohms) |
| $R_{c,sh}$: | Solar cell shunt resistance (ohms) |
| q : | Electron charge = 1.6×10^{-19} C |
| k : | Boltzmann's constant = 1.38×10^{-23} J/K |
| A : | Diode ideal factor ($1 \leq A \leq 2$) |
| G : | Solar irradiance (W/m^2) |
| G_0 : | Reference solar irradiance (W/m^2) = 1000 |
| T_r : | Reference temperature (K) = $25 + 273$ |
| N_s : | Number of series solar cells per module |
| C_T : | Temperature coefficient of the light-generated current (A/K) |
| I_{S0} : | Reference saturation current (A) |
| E_g : | Band gap energy of the material (eV). |

Competing Interests

The authors declare that they have no competing interests.

Acknowledgments

The financial support of Energy Research Institute of the University of Kashan towards this research is hereby acknowledged.

References

- [1] D. L. King, W. E. Boyson, and J. A. Kratochvil, "Analysis of factors influencing the annual energy production of photovoltaic systems," in *Proceedings of the Conference Record of the 29th IEEE Photovoltaic Specialists Conference*, pp. 1356–1361, New Orleans, La, USA, May 2002.
- [2] J.-R. Frish, "New renewable energy resources: (a guide to the future)," *Applied Solar Energy*, vol. 33, pp. 25–35, 1997.
- [3] P. N. Shukla and A. Khare, "Solar photovoltaic energy: the state-of-art," *International Journal of Electrical, Electronics and Computer Engineering*, vol. 3, article 91, 2014.
- [4] E. Despotou, A. Gammal, and B. Fontaine, *Global Market Outlook for Photovoltaics until 2014*, European Photovoltaic Industry Association (EPIA), Brussels, Belgium, 2010.
- [5] B. Ghobadian, G. Najafi, H. Rahimi, and T. F. Yusaf, "Future of renewable energies in Iran," *Renewable and Sustainable Energy Reviews*, vol. 13, no. 3, pp. 689–695, 2009.
- [6] P. Chiradeja and R. Ramakumar, "An approach to quantify the technical benefits of distributed generation," *IEEE Transactions on Energy Conversion*, vol. 19, no. 4, pp. 764–773, 2004.
- [7] N. Tanaka, *Technology Roadmap-Solar Photovoltaic Energy*, International Energy Agency Report, Paris, France, 2010.
- [8] A. E. I. Solaron, "500E HE PV Inverter datasheet," 2011.
- [9] B. Parida, S. Iniyar, and R. Goic, "A review of solar photovoltaic technologies," *Renewable and Sustainable Energy Reviews*, vol. 15, no. 3, pp. 1625–1636, 2011.
- [10] B. Anderson and R. Anderson, *Fundamentals of Semiconductor Devices*, McGraw-Hill, New York, NY, USA, 2004.
- [11] D. L. King, J. A. Kratochvil, and W. E. Boyson, *Photovoltaic Array Performance Model*, Department of Energy, Washington, DC, USA, 2004.
- [12] B. Brooks, "The bakersfield fire," *Solar Pro*, vol. 4, p. p62, 2011.
- [13] P. Ducange, M. Fazzolari, B. Lazzarini, and F. Marcelloni, "An intelligent system for detecting faults in photovoltaic fields," in *Proceedings of the 11th International Conference on Intelligent Systems Design and Applications (ISDA '11)*, pp. 1341–1346, Cordoba, Spain, November 2011.
- [14] T. Takashima, J. Yamaguchi, K. Otani, K. Kato, and M. Ishida, "Experimental studies of failure detection methods in PV module strings," in *Proceedings of the IEEE 4th World Conference on Photovoltaic Energy Conversion (WCPEC '06)*, pp. 2227–2230, IEEE, May 2006.
- [15] M. K. Alam, F. Khan, J. Johnson, and J. Flicker, "A comprehensive review of catastrophic faults in PV arrays: types, detection, and mitigation techniques," *IEEE Journal of Photovoltaics*, vol. 5, no. 3, pp. 982–997, 2015.
- [16] K.-H. Chao, S.-H. Ho, and M.-H. Wang, "Modeling and fault diagnosis of a photovoltaic system," *Electric Power Systems Research*, vol. 78, no. 1, pp. 97–105, 2008.
- [17] T. Takashima, J. Yamaguchi, and M. Ishida, "Disconnection detection using earth capacitance measurement in photovoltaic module string," *Progress in Photovoltaics: Research and Applications*, vol. 16, no. 8, pp. 669–677, 2008.

- [18] Y. Yagi, H. Kishi, R. Hagihara et al., "Diagnostic technology and an expert system for photovoltaic systems using the learning method," *Solar Energy Materials and Solar Cells*, vol. 75, no. 3-4, pp. 655-663, 2003.
- [19] Y. Zhao, *Fault Analysis in Solar Photovoltaic Arrays*, Northeastern University, Boston, Mass, USA, 2010.
- [20] T. Yamada, H. Nakamura, T. Sugiura, K. Sakuta, and K. Kurokawa, "Reflection loss analysis by optical modeling of PV module," *Solar Energy Materials and Solar Cells*, vol. 67, no. 1-4, pp. 405-413, 2001.
- [21] X. H. Nguyen, "Matlab/Simulink based modeling to study effect of partial shadow on solar photovoltaic array," *Environmental Systems Research*, vol. 4, no. 1, 2015.
- [22] S. K. Firth, K. J. Lomas, and S. J. Rees, "A simple model of PV system performance and its use in fault detection," *Solar Energy*, vol. 84, no. 4, pp. 624-635, 2010.
- [23] R. Hammond, D. Srinivasan, A. Harris, K. Whitfield, and J. Wohlgemuth, "Effects of soiling on PV module and radiometer performance," in *Proceedings of the Record of the 26th IEEE Photovoltaic Specialists Conference*, pp. 1121-1124, Anaheim, Calif, USA, September-October 1997.
- [24] K.-H. Chao, C.-J. Li, and S.-H. Ho, "Modeling and fault simulation of photovoltaic generation systems using circuit-based model," in *Proceedings of the IEEE International Conference on Sustainable Energy Technologies (ICSET '08)*, pp. 290-294, November 2008.
- [25] G. Petrone, G. Spagnuolo, R. Teodorescu, M. Veerachary, and M. Vitelli, "Reliability issues in photovoltaic power processing systems," *IEEE Transactions on Industrial Electronics*, vol. 55, no. 7, pp. 2569-2580, 2008.
- [26] M. G. Villalva, J. R. Gazoli, and E. R. Filho, "Comprehensive approach to modeling and simulation of photovoltaic arrays," *IEEE Transactions on Power Electronics*, vol. 24, no. 5, pp. 1198-1208, 2009.
- [27] J. Gow and C. Manning, "Development of a photovoltaic array model for use in power-electronics simulation studies," *IEE Proceedings, Electric Power Application*, vol. 146, no. 2, pp. 193-200, 1999.
- [28] C. R. A. Mermoud and J. Bonvin, *PVSYST, Version 4.37*, University of Geneva, Institut of Environmental Sciences (ISE) Group Energy (FOREL), Geneva, Switzerland, 2009.
- [29] A.-S. P. S. National Electrical Code, 2011.
- [30] J. Flicker and J. Johnson, "Analysis of fuses for Blind Spot ground fault detection in photovoltaic power systems," Sandia National Laboratories Report, 2013.
- [31] H. Patel and V. Agarwal, "MATLAB-based modeling to study the effects of partial shading on PV array characteristics," *IEEE Transactions on Energy Conversion*, vol. 23, no. 1, pp. 302-310, 2008.
- [32] D. D. Nguyen and B. Lehman, "Modeling and simulation of solar PV arrays under changing illumination conditions," in *Proceedings of the 10th IEEE Workshop on Computers in Power Electronics (COMPEL '06)*, pp. 295-299, September 2006.
- [33] N. Heidari, J. Gwamuri, T. Townsend, and J. M. Pearce, "Impact of snow and ground interference on photovoltaic electric system performance," *IEEE Journal of Photovoltaics*, vol. 5, no. 6, pp. 1680-1685, 2015.
- [34] S. Wendlandt, A. Drobisch, T. Buset, S. Krauter, and P. Grunow, "Hot spot risk analysis on silicon cell modules," in *Proceedings of the 25th European Photovoltaic Solar Energy Conference*, Valencia, Spain, September 2010.
- [35] Y. Zhao, B. Lehman, J.-F. de Palma, J. Mosesian, and R. Lyons, "Challenges to overcurrent protection devices under line-line faults in solar photovoltaic arrays," in *Proceedings of the 3rd Annual IEEE Energy Conversion Congress and Exposition (ECCE '11)*, pp. 20-27, Milwaukee, Wis, USA, September 2011.
- [36] Y. Zhao, J.-F. de Palma, J. Mosesian, R. Lyons, and B. Lehman, "Line-line fault analysis and protection challenges in solar photovoltaic arrays," *IEEE Transactions on Industrial Electronics*, vol. 60, no. 9, pp. 3784-3795, 2013.
- [37] K. Xia, Z. He, Y. Yuan, Y. Wang, and P. Xu, "An arc fault detection system for the household photovoltaic inverter according to the DC bus currents," in *Proceedings of the 18th International Conference on Electrical Machines and Systems (ICEMS '15)*, pp. 1687-1690, Pattaya, Thailand, October 2015.
- [38] E. D. Spooner and N. Wilmot, "Safety issues, arcing and fusing in PV arrays," in *Proceedings of the 3rd International Solar Energy Society Conference-Asia Pacific Region*, Sydney, Australia, 2008.
- [39] M. Davarifar, A. Rabhi, and A. E. Hajjaji, "Comprehensive modulation and classification of faults and analysis their effect in DC side of photovoltaic system," *Energy and Power Engineering*, vol. 5, no. 4, pp. 230-236, 2013.
- [40] G. Makrides, B. Zinsser, G. E. Georghiou, M. Schubert, and J. H. Werner, "Degradation of different photovoltaic technologies under field conditions," in *Proceedings of the 35th IEEE Photovoltaic Specialists Conference (PVSC '10)*, pp. 2332-2337, Honolulu, Hawaii, USA, June 2010.
- [41] M. N. Akram and S. Lotfifard, "Modeling and health monitoring of DC side of photovoltaic array," *IEEE Transactions on Sustainable Energy*, vol. 6, no. 4, pp. 1245-1253, 2015.
- [42] C.-C. Hua and P.-K. Ku, "Implementation of a stand-alone photovoltaic lighting system with MPPT, battery charger and high brightness LEDs," in *Proceedings of the 6th International Conference on Power Electronics and Drive Systems (PEDS '05)*, pp. 1601-1605, Honolulu, Hawaii, USA, December 2005.
- [43] Y. Wang, Y. Li, and X. Ruan, "High-accuracy and fast-speed MPPT methods for PV string under partially shaded conditions," *IEEE Transactions on Industrial Electronics*, vol. 63, no. 1, pp. 235-245, 2016.
- [44] F. Schimpf and L. E. Narum, "Recognition of electric arcing in the DC-wiring of photovoltaic systems," in *Proceedings of the 31st International Telecommunications Energy Conference (INTELEC '09)*, pp. 1-6, Incheon, Republic of Korea, October 2009.
- [45] F. Chan and H. Calleja, "Reliability: a new approach in design of inverters for PV systems," in *Proceedings of the 10th IEEE International Power Electronics Congress (CIEP '06)*, pp. 97-102, October 2006.
- [46] A. M. Omer, "Renewable energy resources for electricity generation in Sudan," *Renewable and Sustainable Energy Reviews*, vol. 11, no. 7, pp. 1481-1497, 2007.



Hindawi

Submit your manuscripts at
<http://www.hindawi.com>

