

## Research Letter

# Advances in IP Micromobility Management Using a Mobility-Aware Routing Protocol

Michael Georgiades,<sup>1</sup> Kar Ann Chew,<sup>2</sup> and Rahim Tafazolli<sup>1</sup>

<sup>1</sup> Centre for Communication Systems Research, University of Surrey, Guildford GU2 7XH, UK

<sup>2</sup> Mobility Research Centre, BT Group CTO, Rigel House, Adastral Park, Ipswich IP5 3RE, UK

Correspondence should be addressed to Michael Georgiades, m.georgiades@ieee.org

Received 13 August 2007; Accepted 15 October 2007

Recommended by Amoakoh Gyasi-Agyei

Several micromobility schemes have been proposed to augment Mobile IP and provide a faster and smoother handoff than what is achievable by Mobile IP alone, the majority of which can be categorized into either “network prefix-based” or “host-specific forwarding” mobility management protocols, depending on the routing method used. This letter proposes a mobility-aware routing protocol (MARP) which makes use of both of these routing methods using dynamic IP address allocation. Its performance is evaluated and compared against hierarchical Mobile IP (HMIP) and Cellular IP based on handoff performance, end-to-end delivery delay, and scalability. The results demonstrate that MARP is a more robust, flexible, and scalable micromobility protocol, minimizes session disruption, and offers improvements in handoff performance.

Copyright © 2007 Michael Georgiades et al. This is an open access article distributed under the Creative Commons Attribution License, which permits unrestricted use, distribution, and reproduction in any medium, provided the original work is properly cited.

## 1. INTRODUCTION

The idea of micromobility was introduced after a number of shortcomings were identified with Mobile IP [1] such as non-localized location management, triangular routing impact on packet delivery delay, and inflight packets being lost during handoff [2]. Inflight packets refer to any packets destined to the mobile node (MN) during handover. Since then several micromobility schemes have been proposed to augment Mobile IP and provide a faster and smoother handoff than what is achievable by Mobile IP alone. HMIP [3], Cellular IP [4], HAWAII [5], and IDMP [6] are some examples of micromobility protocols. Moreover, IETF has recently established another working group to deal with network-based localized mobility management (NetLMM) [7].

The majority of these proposals agree that Mobile IP is suitable for handling macromobility (interdomain mobility) but not the micromobility (intradomain mobility)[8]. Network-prefix-based protocols like HMIP usually require the mobile node (MN) to change its IP address as it changes its point of attachment. The change of IP address causes disruption to ongoing sessions not only due to delays in address acquisition, but also to its impact on other IP-dependant protocols. Alternatively, micromobility protocols that use

host-specific forwarding allow MNs to maintain the same IP address but this poses scalability problems as the number of routing entries in the network becomes very high. In addition, these protocols, such as Cellular IP and HAWAII, assume a hierarchical network topology which defeats the robustness and flexibility of an IP routing protocol.

A protocol that does not require an active MN to change its IP address but works on an arbitrary network topology is proposed here. This protocol is known as “mobility-aware routing protocol” or MARP and makes use of network prefix-based as well as host-specific routing to achieve this.

## 2. OPERATION OF MARP

A dynamic IP address allocation mechanism is suggested for MARP. Each access router (AR) owns a block of IP addresses and IP routing algorithm runs on this address prefix. Figure 1 is used as an example to illustrate the basic operation of MARP. When an MN first attaches to an AR (R1), it is assigned one of the addresses of the AR. The IP address is topologically correct, that is, it has the same network prefix as the AR. This router is designated as the allocating access router (AAR). As long as the MN is connected to AAR, conventional network-prefix-based routing is used to route packets to MN

as per norm. In this example, packets destined to the MN while connected to R1 will go via the following route: Gateway (GW), R5, R4, R3, and R1.

As the MN moves to a new access router (NAR) R2, route update requests are sent towards the GW, AAR, and old access routes (OARs). The NAR is then acknowledged by route update reply messages that the routing path(s) have been updated. When this is done, host-specific entries (HSEs) overwrite the routing entries in R3 but not in R4 and R5 whose network-prefix-based routing entries targeting AAR are sufficient for forwarding packets towards R2. Moreover, an HSE is also installed in AAR and any OARs. This enables the redirection of packets that would otherwise be lost in flight whilst the new host-specific route is being installed. The idea of creating forwarding entries between NAR and OAR is similar to the fast handoff operation for Mobile IPv6 that creates a temporary tunnel between NAR and OAR as specified in [9]. When the mobile “switches off” or moves to idle mode, the IP address is returned to the AAR, and the host-specific routes are deleted either by explicit signaling or upon timer expiry. Note that a paging function based on [3] is also incorporated in MARP. As described, micromobility complements Mobile IP which is the default macromobility protocol. If the MN is at a foreign network, it also performs a registration and binding update with its HA and its corresponding node (CN), according to the specification of Mobile IP.

### 3. PERFORMANCE EVALUATION

The performance of MARP was evaluated by a simulation model implemented in OPNET [10]. OPNET Modeler is used by some of the world’s largest network equipment manufacturers to accelerate the R&D of network devices and technologies, and offers a comprehensive library of detailed protocol and application models when it comes to IP-related technologies. MARP was compared to Cellular IPv6 and HMIP which were modeled based on the latest IETF-drafts, [3, 11], respectively.

#### 3.1. Simulation model

Figure 2 shows the network level view of the model. It consists of a Mobile IP home agent (HA), a GW, 16 ARs, and a variable number of MNs. The traffic-source and traffic-sink nodes represent correspondent nodes (CNs) of MNs as packet sender and receiver, respectively. The MNs move within the network (coverage area of 800 m × 800 m) and can attach to any of the 16 ARs (each covering 100 m × 100 m). A bursty ON/OFF traffic source is used with a rate of 50 packets per second during the ON period.

The mobility model used in the simulations is a random waypoint model with mean-pause time of 60 seconds, which is exponentially distributed, and a velocity selected from a predefined range. An ideal wireless model that assumes perfect coverage, no propagation delay, and no transmission errors is used. Hence, packets transmitted over the wireless interface encounter no transmission error or loss. All routers are assumed to have an unlimited buffer size. As such, the only reason for packet loss is merely due to interruption dur-

ing handoff. Furthermore, handoffs at layer two and below are instantaneous, that is, hard handoffs. All fixed links are of 10 Mbps, with delay of 5 milliseconds, whereas the effective data rate of wireless link is 1.5 Mbps. Timer values associated with the MN mobility states for MARP are the same as in [4], that is, ready time (30 seconds), route update time (3 seconds), route timeout (9 seconds), paging update time (180 seconds), and paging timeout (540 seconds).

#### 3.2. Handoff performance

The handoff performance is first studied with focus on the packet loss during handover execution. The ON/OFF traffic model, used in the simulation model, allows the MNs to alternate between active and idle modes. Figure 3 shows the mean packet loss ratio ( $\bar{\rho}$ ) for different MN speeds of motion used for the simulation.  $\bar{\rho}$  is obtained by running the simulation several times, recording the packet loss ratio at all involved MNs, and obtaining the average as

$$\bar{\rho} = \frac{1}{nm} \sum_{j=1}^n \sum_{i=1}^m \frac{\delta_{ji}}{\epsilon_j}, \quad \text{where } \epsilon_j = \beta_j t_{\text{ON}}; \quad (1)$$

$\delta_{ji}$  is the number of packets lost during a handover at one MN;  $\epsilon_j$  is the number of packets sent to that MN within the time interval  $t_{\text{ON}}$ ;  $\beta_j$  is the packet interarrival rate at CN;  $t_{\text{ON}}$  is the time for which CN is active;  $m$  is the number of MNs; and  $n$  is the total number of simulation runs.

MARP gives the best handoff performance among the three protocols, offering the least packet loss. This is because of the route updates sent to the OARs and AAR by the MN which ensures that packets are diverted towards the MN’s current AR. Hence, inflight packets are not lost during a handoff for MARP. Note that if HMIP implements fast handover, its performance is closer to MARP. However, MARP would still establish a better handover performance as HMIP will have to wait for DHCP to complete.

#### 3.3. Scalability

Figure 4 shows the maximum as well as the average number of HSEs created in the ARs (including the GW) for all three schemes. Here, HSEs refer to any routing entry created for an MN, namely, route cache in Cellular IP, binding cache in HMIP, and host-specific forwarding entry in MARP.

It can be seen that the number of HSEs for Cellular IP is consistently higher than that of MARP and HMIP. The number of HSEs is significantly lower for MARP as not all MNs require an HSE in the GW. This is because for stationary MNs or MNs which do not move away from their AAR, the normal IP network-prefix-based routing is sufficient for delivering packets to an MN and hence no new HSEs need to be created. In addition, HSEs are only created in limited number of ARs based on the rule described in Section 2.

#### 3.4. Delivery delay

The three schemes are further compared in terms of end-to-end packet delivery delay. Data delivery in this case is based

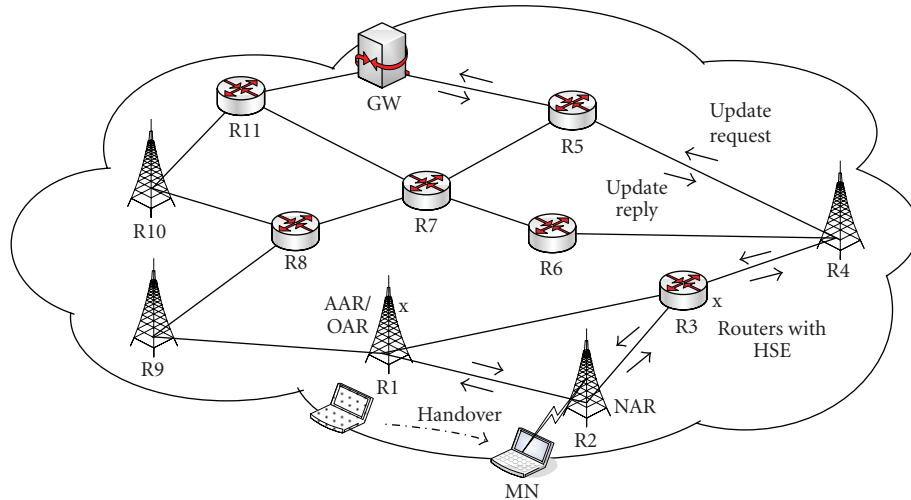

FIGURE 1: An example illustrating how MARP operates.

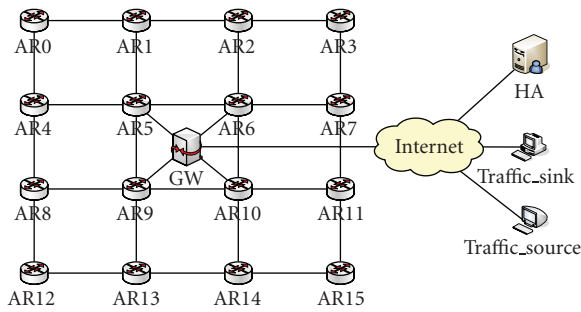

FIGURE 2: Simulation model (Network level view).

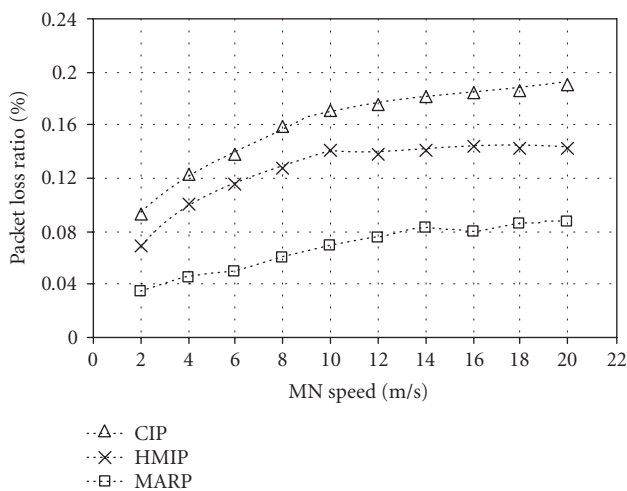

FIGURE 3: Mean packet loss ratio versus MN speed.

on communication between an MN and a CN within the same micromobility domain. This is to reduce the effect and uncertainty of delay created in the global Internet and to

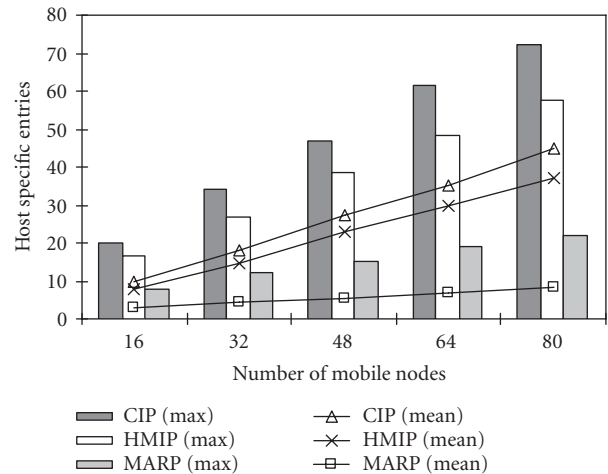

FIGURE 4: Total number of HSEs in ARs & GW.

focus on local mobility. Since the focus of this set of simulation is on packet delivery delay rather than the handoff performance, a less dynamic mobility was used. MNs are moving at a speed of 5 m/s and a mean pause time of 120 seconds.

Figure 5 shows the end-to-end data packet delivery delay for different network loads in the model. It shows that HMIP and MARP perform better than Cellular IP. This is because both HMIP and MARP always use the optimum path to deliver packet from CN to MN. In contrast, Cellular IP makes use of per-host forwarding entries exclusively and sets up tree-based hierarchical delivery path between CN and GW and between MN and GW. All packets created by CN are first routed towards the GW, and then delivered downlink to the MN using the forwarding entry in all the ARs involved. Such delivery path does not make use of alternative shorter paths available between MN and CN. This results in longer end-to-end delivery delay.

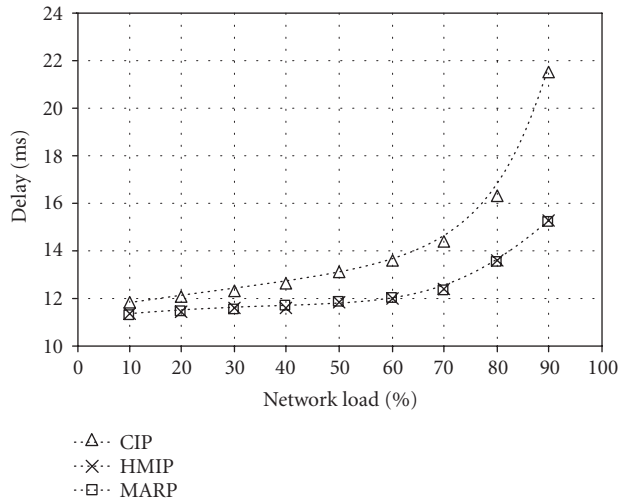

FIGURE 5: End-to-end intradomain delivery delay.

#### 4. CONCLUSION

MARP eliminates some common deficiencies of micromobility protocols but retains the salient features. It makes use of both network-prefix-based routing and host-specific forwarding but HSEs are only limited to a small set of routers thereby reducing the size of forwarding table. This makes MARP scalable while effectively tackling intradomain mobility of MN on per-host basis. The routers with MARP capability can be deployed in the Mobile IP network in a seamless way as it interoperates with Mobile IP as well as with the conventional prefix-based IP routing.

#### REFERENCES

- [1] C. E. Perkins, "IP mobility support for IPv4," RFC 3344, IETF, August 2002.
- [2] I. F. Akyildiz, J. Xie, and S. Mohanty, "A survey of mobility management in next-generation all-IP-based wireless systems," *IEEE Wireless Communications*, vol. 11, no. 4, pp. 16–28, 2004.
- [3] H. Soliman, C. Castelluccia, K. El Malki, and L. Bellier, "Hierarchical MIPv6 mobility management (HMIPv6)," RFC 4140, IETF, August 2005.
- [4] A. T. Campbell, J. Gomez, S. Kim, A. G. Valko, C.-Y. Wan, and Z. R. Turanyi, "Design, implementation, and evaluation of cellular IP," *IEEE Personal Communications*, vol. 7, no. 4, pp. 42–49, 2000.
- [5] R. Ramjee, K. Varadhan, L. Salgarelli, S. R. Thuel, S.-Y. Wang, and T. La Porta, "HAWAII: a domain-based approach for supporting mobility in wide-area wireless networks," *IEEE/ACM Transactions on Networking*, vol. 10, no. 3, pp. 396–410, 2002.
- [6] A. Misra, S. Das, A. Dutta, A. McAuley, and S. K. Das, "IDMP-based fast handoffs and paging in IP-based 4G mobile networks," *IEEE Communications Magazine*, vol. 40, no. 3, pp. 138–145, 2002.
- [7] J. Kempf, "Problem statement for network-based localized mobility management," draft-ietf-netlmm-nohost-ps-05, IETF, September 2006.
- [8] A. T. Campbell, J. Gomez, S. Kim, C.-Y. Wan, Z. R. Turanyi, and A. G. Valko, "Comparison of IP micromobility protocols," *IEEE Wireless Communications*, vol. 9, no. 1, pp. 72–82, 2002.
- [9] R. Koodli, "Fast handovers for mobile IPv6," RFC 4068, IETF, July 2005.
- [10] OPNET, "OPNET modeler wireless suite," OPNET Technologies, 2007, <http://www.opnet.com/>.
- [11] Z. D. Shelby, D. Gatzounas, A. T. Campbell, and C.-Y. Wan, "Cellular IPv6," IETF, July 2001.



**Hindawi**

Submit your manuscripts at  
<http://www.hindawi.com>

