

Research Article

Four-Port Dual-Mode Diplexer with High Signal Isolation

Jessada Konpang¹ and Natchayathorn Wattikornsirikul² 

¹Department of Electronic and Telecommunication Engineering, Faculty of Engineering, Rajamangala University of Technology Krungthep, 2 Nang Linchi Rd, Bangkok, Thailand

²Department of Electronic and Telecommunication Engineering, Faculty of Engineering, Rajamangala University of Technology Phranakhon, Pracharat 1 Rd, Bangkok 1381, Thailand

Correspondence should be addressed to Natchayathorn Wattikornsirikul; natchayathorn.w@mutp.ac.th

Received 4 September 2019; Revised 17 November 2019; Accepted 6 January 2020; Published 10 February 2020

Academic Editor: Stephan Gift

Copyright © 2020 Jessada Konpang and Natchayathorn Wattikornsirikul. This is an open access article distributed under the Creative Commons Attribution License, which permits unrestricted use, distribution, and reproduction in any medium, provided the original work is properly cited.

An ease of four-port dual-mode diplexer with high signal isolation is presented. A compact dual-mode diplexer with high signal isolation between the Rx and Tx modules is achievable by only using one resonator filter topology. Two back-to-back dual-mode diplexers have a 180° phase shift in one branch. The high isolation can be achieved by amplitude and phase cancellation technique. The delayed transmission line can be easily achieved by the phase shifter. The simulated and measured four-port dual-mode diplexers are designed at the centre frequency of Rx/Tx at 1.95 GHz and 2.14 GHz, respectively. The measured results of Rx/Tx dual-mode diplexer devices are presented with 47.1 dB Rx/Tx isolation. This four-port dual-mode diplexer achieves the isolation (S_{32}) of more than 24.1 dB when compared with the conventional three-port dual-mode diplexer structure.

1. Introduction

In RF front-ends of several communication systems, a diplexer is usually used to discriminate two different signal frequency bands for transmitting (Tx) and receiving (Rx) channels while sharing a single antenna. Diplexer structure is composed of two bandpass filters with different passband frequencies. In multiband communications, filters and diplexer are recently required to design with compact size, light weight, and high signal isolation. Microstrip bandpass filters can be easily mounted on a dielectric substrate and can provide a more flexible design of the circuit layout [1]. To keep small circuit size and light weight, common microstrip resonators are employed for filters and diplexer design. The microstrip open-loop resonator filters are highly desirable in the wireless communication systems with compactness and high performance [2]. Many research studies have been performed on compact resonator filters and diplexers such as stepped impedance open-loop resonators [3], compact open-loop resonator filter structure [4], and microstrip square open-loop with stepped-impedance resonator filter and diplexer [5].

Furthermore, it is difficult to apply the high isolation technique for multiband application as the coupling area is constrained by the size of the common resonator and high-order filters. Therefore, it is challenging to design diplexer circuit with high signal isolation and small circuit size. When the signal transmitting power is too high in the diplexer device, the leakage of high signal power from transmitting channels increases. The channel interference between Tx/Rx ports can destroy Rx components in consequence of high transmitting signal. High signal isolation between Tx/Rx ports can be increased by using an ease of structure design; many research papers have been made to increase the signal isolation in diplexers. A lot of efforts to design filters and diplexers have been made on increasing the signal isolation in and out of the band of diplexer [6–11]. To achieve high Tx/Rx isolation signal, the common diplexer designs require high-order filters. As a result of a very complicated filter design and fabrication process, the insertion loss of the filter and diplexer can increase. Moreover, an alternative technique to design diplexer with low cost, high signal isolation, and ease of fabrication process was introduced by using four-port network [12, 13]. The realized microstrip filter

prototype with small circuit size can be achieved by this technique. The technique for size reduction and high isolation signal by using a dual-mode resonator filter and diplexer is presented in [14, 15].

In this paper, an ease of four-port dual-mode diplexer with high signal isolation is presented. The dual-mode structure by using U-shaped resonator with open stub enables a compact and ease of design. High signal isolation between the Tx and Rx module is achievable by only using one resonator filter topology. Two back-to-back three-port dual-mode diplexers and a 180° phase shifter are easily employed to construct the proposed device, which are combined to form a four-port dual-mode diplexer. The high signal isolation can be achieved by amplitude and phase cancellation technique. In order to cancel the same amplitude signal but different phase in transmitter and receiver, a delayed microstrip transmission line can be used to achieve a 180° phase shift in one branch.

1.1. Dual-Mode Resonator Filter Analysis. The concept of four-port dual-mode diplexer is based on a dual-mode resonator filter design. The topology of four-port dual-mode diplexer is formed of two conventional three-port dual-mode diplexers joined back-to-back and a 180° phase shifter as illustrated in Figure 1.

To verify the validation of the concept idea and experiment, the microstrip dual-mode resonator structure can be introduced as an example. The design of dual-mode resonator filter is based on a single-mode open-loop resonator [16,17] which focuses only on the odd-mode resonance. Actually, an even-mode resonance of the single-mode resonator is present approximately at twice the fundamental resonant frequency, and the even mode is of little use in single band resonator filter synthesis. The even mode will emerge as the first spurious response which degrades the filter performance. On the other hand, the even mode of dual-mode filters may also be used as a doubly tuned circuit [18].

For this reason, an open-loop filter may be adjusted to act as a doubly tuned filter. Based on the proposed structure in [18,19], the even-mode resonance can be tuned to close the operating frequency band (the odd mode). Therefore, a second-order response filter can be created by these two poles. The schematic circuit of the dual-mode filter is depicted in Figure 2. The open-circuited stub is added in the centre of the U-shaped resonator filter to lower the even-mode resonant frequency. The extended stub shown has no effect on the odd mode [18]. Therefore, the two modes (odd and even modes) can be tuned independently.

The equivalent circuits of even and odd modes at the resonant mode are shown in Figure 3. An open-circuited half wavelength-type resonator shows the even mode resonator as Figure 3(a) while a short-circuited quarter wavelength-type resonator shows the odd mode as in Figure 3(b).

The dual-mode resonator by using a U-shaped resonator with open stub can be illustrated as an example design. The open-circuited stub can be used to tune the even mode of dual-mode performance [19]. The dual-mode resonator

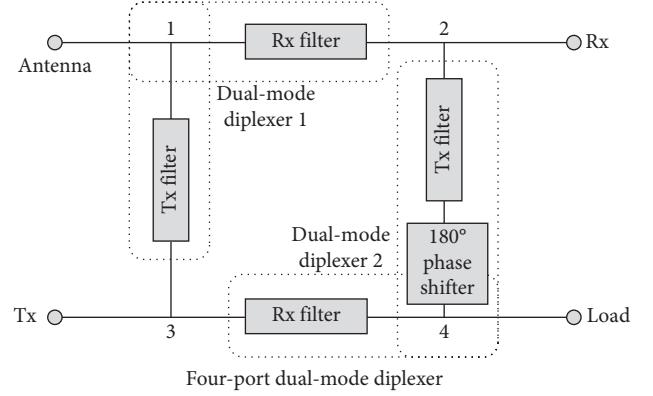

FIGURE 1: Topology of four-port dual-mode diplexer.

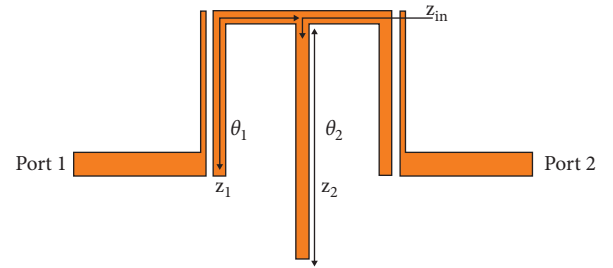

FIGURE 2: Dual-mode microstrip U-shaped resonator with open stub.

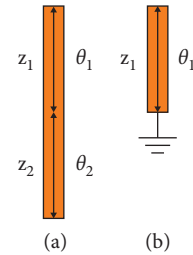

FIGURE 3: (a) Even-mode resonator. (b) Odd-mode resonator.

consists of two sections of the same impedances as illustrated in Figure 2. Dimensions were calculated using the following equation:

$$\theta_1 \cong \frac{\pi}{2}. \quad (1)$$

The open-circuited stub (Z_2) connects to the middle of the resonator (Z_1). αZ_2 represents the even-mode equivalent impedances of the sections with impedance Z_2 . The electrical length (θ_2 of the open-circuited stub) may be defined from

$$\theta_1 \cong \pi - \left(\frac{c}{4 f_{\text{odd}} \sqrt{\epsilon_{\text{eff}}}} \right), \quad (2)$$

where θ_x ($x = 1, 2, 3$) corresponds to the electrical length of the section in Figure 1 and c is the speed of light in vacuum.

To demonstrate the proposed dual-mode microstrip filters, the resonators are of U shape which is loaded by an open-end stub. The filters are designed on a RT/Duroid

substrate having a thickness $h = 1.27$ mm with a relative dielectric constant $\epsilon_r = 6.15$. The filters were simulated by IE3D full-wave EM simulations. The input and output coupled-feed lines are used to couple the signal to the dual-mode resonator having a line width (cf) and coupling spacing (g). The odd and even modes are referred to as the first two resonating modes. These two modes can have the same or different modal frequencies which depend on the lengths of the open stub. The basic structure of a dual-mode microstrip resonator is pictured in Figure 4.

The operational frequencies compared to the first spurious mode by tuning the open-stub lengths have been investigated using IE3D full-wave EM simulations. The dual-mode resonator is designed to achieve the desired resonant frequencies by fixing the length of the U -shaped resonator (a and c). Even-mode characteristic can be achieved by adjusting the length of open-circuit stub loaded (b). Two input/output microstrip lines with $50\ \Omega$ characteristic impedance are used to feed the proposed dual-mode resonator with open-stub loaded resonator. As can be seen in Figure 5, the open-stub loaded length does not affect the S_{21} response at odd-mode resonant frequency while the even-mode resonant frequency is flexibly controlled by changing the length of open stub (b). An inherent transmission zero (TZ) causes an asymmetric response. As the resonator is coupled to the input and output ports with a coupling-feed structure, the first two resonating modes are referred to as the odd and even modes. These two modes can have the same or different modal frequencies depending on the dimensions of the resonator. Moreover, when the two modes split, a finite transmission zero is produced on the high side of the two modes when even mode frequency is higher than the odd mode frequency. The major outcome of this property is realization of filters with an asymmetrical frequency response (the upper stopband of the filter).

1.2. Design of Four-Port Dual-Mode Diplexer. The layout structure of the proposed four-port microstrip dual-mode diplexer is presented in Figure 6(a). The Tx/Rx filters are interconnected by an appropriately designed matching circuit of T-junction that has the width of the $50\ \Omega$ line. The diplexer geometry is optimized at the T-junction for better return loss performance in both the channels. It is noted that using port 1 with an impedance of $50\ \Omega$ as the feed line has advantages of obtaining better diplexer insertion loss and rejection performances. Here, the lengths of the T-junction are optimized such that each filter in the diplexer should look like an open circuit to the other filter at its centre frequency.

Four-port dual-mode diplexer layout is formed of two conventional three-port dual-mode diplexers joined back-to-back and a 180° phase shifter. The design technique based on two diplexers is joined back-to-back to form the four-port diplexer. A 180° phase shifter is added in one of the channel filters between port 2 and port 4. To achieve such a phase shifter, a half wavelength delayed line is adopted. A phase shift of $180^\circ \pm 2^\circ$ is achieved across the Tx and Rx bands.

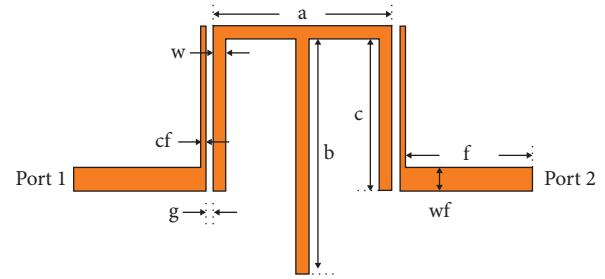

FIGURE 4: Schematic structure of the dual-mode microstrip resonator with input/output coupled feed.

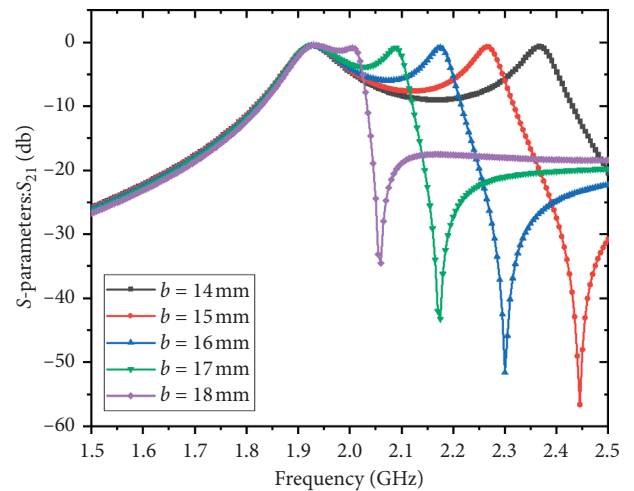

FIGURE 5: Simulated response of transmission zero located at the upper side of the operating frequency with different lengths of loaded open stub.

The significant change in isolation from a 3-port to a 4-port type is that if we allow the antenna impedance to change, we can tune the load impedance (port 4) to compensate for the antenna mismatch and recover the isolation back again. Thus, the effects of a mismatched antenna port are considered and recovered by using the 4-port type. The photograph of four-port dual-mode prototype is shown in Figure 6(b). The milling machine can be used to fabricate the circuit pattern. The dimensions of the four-port microstrip dual-mode diplexer are detailed in Table 1.

Measurements are carried out using an Agilent Vector Network analyzer. The measured and simulated results of the four-port dual-mode diplexer are shown in Figure 7(a). The measured in-band return loss is better than 25 dB in the first bandpass (1.95 GHz) and 24 dB in the second bandpass (2.14 GHz), respectively. The insertion losses are approximately 1.1/1.16 dB at the two bandpasses. The simulation and measurement results are in good agreement. The comparison of signal isolation, S_{32} , of the isolation of four-port dual-mode diplexer and three-port dual-mode diplexer between the Rx and Tx bands is shown in Figure 7(b). The measured signal isolation of the conventional three-port dual-mode diplexer is 23 dB, and it is 47.1 dB for the four-port dual-mode diplexer. The excess losses in the measurements are

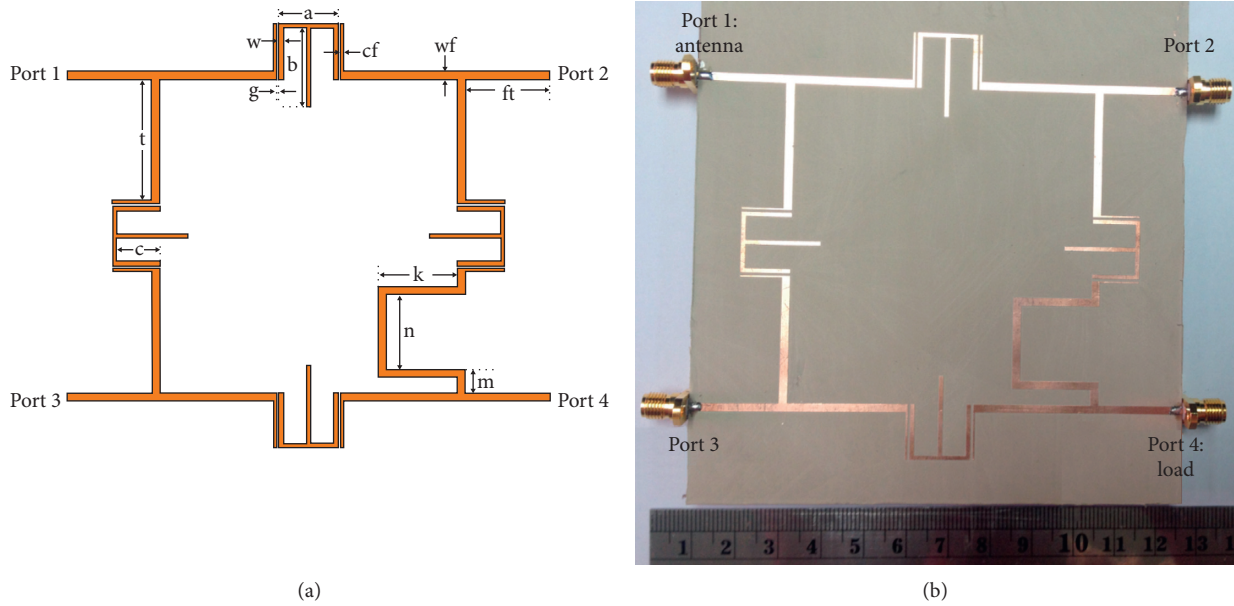

FIGURE 6: (a) Layout. (b) Photograph of four-port dual-mode diplexer.

TABLE 1: Dimensions of four-port microstrip dual-mode resonator diplexer.

Dimensions	$R_x = 1.95 \text{ GHz}$	$T_x = 2.14 \text{ GHz}$
Resonator width (w)	1 mm	1 mm
Feed width (wf)	1.87 mm	1.87 mm
Coupling-feed width (cf)	0.4 mm	0.4 mm
Space between coupling feed and dual-mode resonator (g)	0.6 mm	0.6 mm
Resonator length (a)	14 mm	14 mm
Resonator length (b)	18.5 mm	16.9 mm
Resonator length (c)	11.94 mm	10.2 mm
Feed length (ft)	19.8 mm	19.8 mm
T-junction length (t)	29.35 mm	27.05 mm
Delayed-line length (k)		18.5 mm
Microstrip line length (m)		5.58 mm
Delayed-line length (n)		17.7 mm

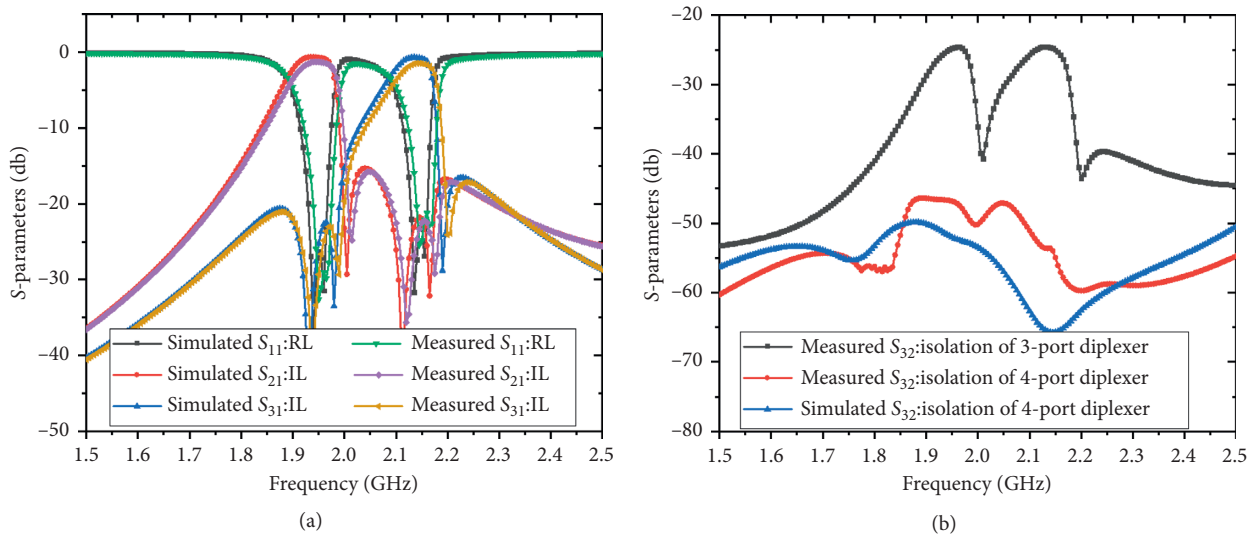

FIGURE 7: Comparison between simulated and measured results of (a) RL and IL of four-port diplexer and (b) isolation (S_{32}) between three-port diplexer and four-port diplexer.

believed to be due to the SMA connectors and fabrication errors.

To compare the size of the proposed four-port dual-mode diplexer, a conventional four-port diplexer [13] is simulated by using a single-mode microstrip open-loop resonator. The total number of degrees required in a single-mode bandpass filter can be reduced by half for dual-mode resonators. High signal isolation between the Tx and Rx modules is achievable by only using one resonator filter topology. Moreover, the four-port microstrip dual-mode diplexer still reduces overall signal losses with the same or better isolation compared to the existing state-of-the-art diplexers [13].

2. Conclusions

A four-port dual-mode diplexer with high signal isolation based on amplitude and phase cancellation technique is presented. A small dual-mode bandpass filter with high signal isolation between the Tx and Rx modules is achievable by only using one resonator filter topology. Two back-to-back dual-mode diplexers have a 180° phase shift in one branch. The high isolation can be achieved by amplitude and phase cancellation technique. The delayed transmission line can be easily achieved by the phase shifter. The four-port microstrip dual-mode diplexer can enhance the isolation (S_{32}) to more than 24.1 dB from the conventional three-port diplexer. Finally, the low complexity design and ease of fabrication process are proposed by using a four-port dual-mode diplexer which can be used in wireless communications.

Data Availability

The data that support the findings of this study are included in the article.

Conflicts of Interest

The authors declare that they have no conflicts of interest.

Acknowledgments

The authors thank the Department of Electronic and Telecommunication Engineering, Faculty of Engineering, Rajamangala University of Technology Phranakho, and Department of Electronic and Telecommunication Engineering, Faculty of Engineering, Rajamangala University of Technology Krungthep, for supporting the research successfully.

References

- [1] D. M. Pozar, *Microwave Engineering*, Wiley, New York, NY, USA, 2nd edition, 1998.
- [2] J.-S. Hong and M. J. Lancaster, *Microstrip Filter for RF/Microwave Applications*, Wiley, New York, NY, USA, 2001.
- [3] S. S. Oh and Y. S. Kim, "A compact duplexer for IMT-2000 handsets using microstrip slow-wave open-loop resonators with high-impedance meander lines," *Radio and Wireless Conference*, vol. 177–180, 2001.
- [4] E. Goron, J.-P. Coupez, C. Person, Y. Toutain, H. Lattard, and F. Perrot, "Accessing to UMTS filtering specifications using new microstrip miniaturized loop-filters," in *Proceedings of the IEEE MTT-S International Microwave Symposium Digest*, Philadelphia, PA, USA, June 2003.
- [5] J. Konpang, "A compact diplexer using square open loop with stepped impedance resonators," *Asia-Pacific Microwave Conference*, vol. 1–4, 2008.
- [6] H.-S. Peng and Y.-C. Chiang, "Microstrip diplexer constructed with new types of dual-mode ring filters," *IEEE Microwave and Wireless Components Letters*, vol. 25, no. 1, pp. 7–9, 2015.
- [7] T. Yang, P.-L. Chi, and T. Itoh, "High isolation and compact diplexer using the hybrid resonators," *IEEE Microwave and Wireless Components Letters*, vol. 20, no. 10, pp. 551–553, 2010.
- [8] X. Guan, F. Yang, H. Liu, and L. Zhu, "Compact and high-isolation diplexer using dual-mode stub-loaded resonators," *IEEE Microwave and Wireless Components Letters*, vol. 24, no. 6, pp. 385–387, 2014.
- [9] F. Cheng, X. Q. Lin, Z. B. Zhu, L. Y. Wang, and Y. Fan, "High isolation diplexer using quarter-wavelength resonator filter," *Electronics Letters*, vol. 48, no. 6, pp. 330–331, 2012.
- [10] J.-K. Xiao, M. Zhu, Y. Li, L. Tian, and J.-G. Ma, "High selective microstrip bandpass filter and diplexer with mixed electromagnetic coupling," *IEEE Microwave and Wireless Components Letters*, vol. 25, no. 12, pp. 781–783, 2015.
- [11] J.-X. Xu and X. Y. Zhang, "Compact high-isolation LTCC diplexer using common stub-loaded resonator with controllable frequencies and bandwidths," *IEEE Transactions on Microwave Theory and Techniques*, vol. 65, 2017.
- [12] J. Konpang, M. Sandhu, N. Somjit, and I. Hunter, "Novel RF interference rejection technique using a four-port diplexer," in *Proceedings of the European Microwave Conference*, London, UK, October 2016.
- [13] J. Konpang, M. Sandhu, N. Somjit, and I. Hunter, "Four-port microstrip diplexer for RF interference rejection," in *Proceedings of the 2016 13th International Conference on Electrical Engineering/Electronics, Computer, Telecommunications And Information Technology, ECTI-CON 2016*, Chiang Mai, Thailand, June 2016.
- [14] V. K. Velidi, U. Prabhakaran, A. V. G. Subramanyam, D. Sivareddy, and V. V. Srinivasan, "Design of compact microstrip diplexer with high selectivity," in *Proceedings of the Signal Processing and Communications International Conference (SPCOM)*, Bangalore, Karnataka, July 2012.
- [15] N. Wattikornsirikul and M. Kumngern, "Dual-mode diplexer with high isolation based on amplitude and phase cancellation technique," *Progress In Electromagnetics Research M*, vol. 76, pp. 187–195, 2018.
- [16] J.-S. Hong and M. J. Lancaster, "Theory and experiment of novel microstrip slow-wave open-loop resonator filters," *IEEE Transactions on Microwave Theory and Techniques*, vol. 45, no. 12, pp. 2358–2365, 1997.
- [17] J.-S. Hong and M. J. Lancaster, "Design of highly selective microstrip bandpass filters with a single pair of attenuation poles at finite frequencies," *IEEE Transactions on Microwave Theory and Techniques*, vol. 48, no. 7, pp. 1098–1107, 2000.
- [18] L. Athukorala, D. Budimir, and M. M. Potrebic, "Design of open-loop dual-mode microstrip filters," *Progress in Electromagnetics Research Letters*, vol. 19, pp. 179–185, 2010.
- [19] J.-S. Hong, H. Shaman, and Y.-H. Chun, "Dual-mode microstrip open-loop resonators and filters," *IEEE Transactions on Microwave Theory and Techniques*, vol. 55, no. 8, pp. 1764–1770, 2007.